

JULY, 1954

JUL 26 1954

Radio-Television
**SERVICE
DEALER**

TV - AM - FM - SOUND

Includes: **"VIDEO SPEED SERVICING"**
"TV FIELD SERVICE" *Data Sheet Sections*



The Professional Radio-TVman's Magazine
Reaching Every Radio TV Service Firm Owner in the U.S.A.



ASSURED ELECTRICAL ACCURACY

BASED ON MANUFACTURERS' PROCUREMENT PRINTS

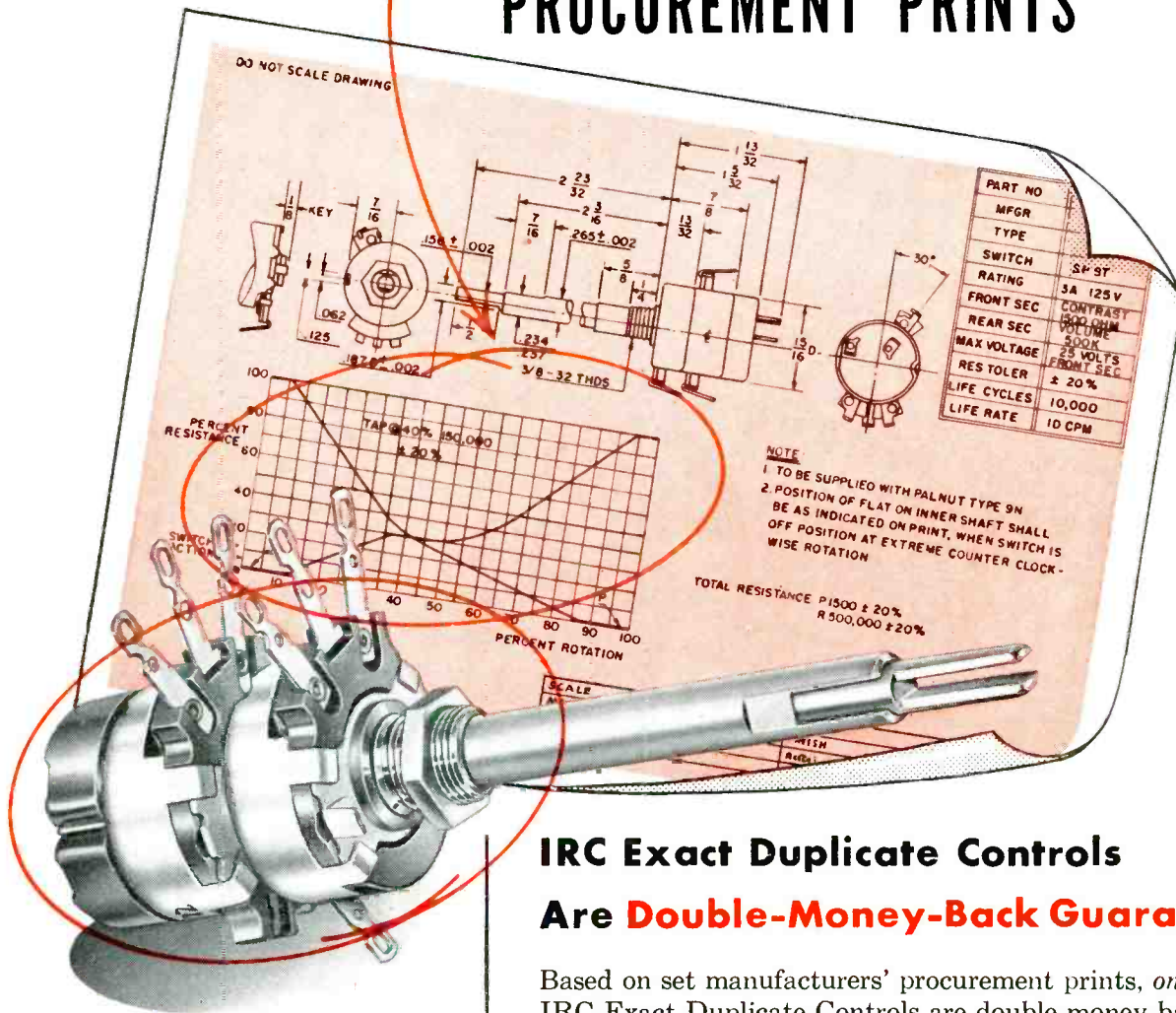

**ONLY IRC GUARANTEES
ACCURATE ELECTRICAL OPERATION
AND SATISFACTORY MECHANICAL FIT
OR DOUBLE-YOUR-MONEY-BACK**

Electrical specifications of this typical manufacturer's procurement print are exactly duplicated by IRC's QJ-412 control (shown). CONCENTRIKIT assembly includes P1-206 and R1-223 shafts with B17-109 and B13-133X Base Elements and 76-1 Switch.



Wherever the Circuit Says ~~~

IRC Exact Duplicate Controls Are Double-Money-Back Guaranteed

Based on set manufacturers' procurement prints, *only* IRC Exact Duplicate Controls are double-money-back guaranteed for accurate electrical operation. This firm guarantee applies to both IRC factory-assembled Exact Duplicates *and* universal CONCENTRIKIT equivalents.

Set manufacturers' electrical specifications are closely followed.

Resistance values are carefully selected to match.

Tapers are watched carefully; IRC doesn't arbitrarily substitute tapers to obtain wide coverage.

For exact duplicate controls of guaranteed accuracy, specify IRC. Most Service Technicians do.

INTERNATIONAL RESISTANCE CO.

413 N. Broad Street, Philadelphia 8, Pa.

In Canada: International Resistance Co., Ltd., Toronto, Licensee



A first PERFORMANCE

Introducing the longest line of replacement loud speakers with the lowest inventory requirement.

The highest performance in replacement loud speakers at the lowest cost.

THE NEW Viking Replacement Speakers by JENSEN.

Completely redesigned for all today's requirements, the new Viking speakers are completely streamlined both for stocking, selling and performance. Viking is the most complete line for radio, TV, replacement and general purpose applications—there are 13 models including 3 ovals

BUT

because of the ingenuity of the Jensen design, you need only one universally applicable model in each speaker size. Your inventory requirements are lower than for any other speaker line—your stock investment is cut to the bone.

And the Viking speakers are universal. The new Viking design is the most compact, has the least depth of all the replacement speakers. They'll fit into even the most crowded sets. And with the most compact design Viking has introduced greatly improved efficiency, heavier magnets, truly permanent alignment, at no increase in price in all models 6" and smaller.

Free with all sizes from 3" to 6" Viking speakers new free, easy-mount combination transformer and chassis mount bracket.

Jensen

MANUFACTURING COMPANY

Division of The Muter Company
 6601 South Laramie Avenue • Chicago 38, Illinois
 In Canada: COPPER WIRE PRODUCTS, LTD., Licensee

GET OFF THE SPOT

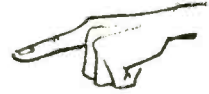

AND
INTO
THE
SPOTLIGHT



WITH THE



BONDED ELECTRONIC TECHNICIAN PROGRAM

Once you gain the confidence of customers, you're on your way to increased volume and profits. The Raytheon *Bonded* Electronic Technician program is designed to help you do just that. The Raytheon Registered Bond Certificate, the Raytheon Creed Display Decal and Identification Cards, featuring your bonded status and the fine Raytheon "Code of Ethics", inspire customer confidence. And a recent survey proved that wherever Raytheon Bonded

Technicians took full advantage of their Bonded status — used it to inspire customer confidence — business improved by *at least ten per cent.*

Ask your Raytheon Tube Distributor if you can qualify for this important sales advantage. If you can, the bond is yours *at no cost to you* — it is *Raytheon's investment in your future.*



RAYTHEON MANUFACTURING COMPANY

Receiving Tube Division
Newton, Mass., Chicago, Ill., Atlanta, Ga., Los Angeles, Cal.

RAYTHEON MAKES ALL THESE:

RECEIVING AND PICTURE TUBES • RELIABLE SUBMINIATURE AND MINIATURE TUBES • SEMICONDUCTOR DIODES AND TRANSISTORS • NUCLEONIC TUBES • MICROWAVE TUBES



Excellence in Electronics



Every Service Firm Owner in the U.S.A.
Receives SERVICE DEALER Monthly
DISTRIBUTION THIS ISSUE OVER 65,000

COWAN PUBLISHING CORP., 67 West 44th Street, New York 36, N. Y.

VOL. 15, NO. 7

JULY, 1954

EDITORIAL STAFF

Publisher

SANFORD R. COWAN

Editor

SAMUEL L. MARSHALL

Editorial Production

ROBERT CAMPBELL

Contributing Editors

LEONARD LIEBERMAN

ROBERT T. DARGAN

PAUL GOLDBERG

MARVIN KLEIN

SAN D'ARCY

BUSINESS STAFF

Advertising Director

SANFORD L. CAHN

Advertising Manager

HARRY N. REIZES

Advertising Sales

LAWRENCE STEINER

Production Manager

DAVID SALTMAN

Circulation Manager

HAROLD WEISNER

BRANCH OFFICES

LOS ANGELES

TED E. SCHELL

2700 West Third Street

Dunkirk 2-4889

CLEVELAND

RICHARD E. CLEARY

Commercial Bank Bldg.

Berea, Ohio

Berea 4-7719

FEATURE ARTICLES

TV Instrument Clinic, Part 3, by Robert G. Middleton	7
A perceptive discussion of test problems based on the author's Challenge Clinic demonstrations.	
Horizontal and High Voltage Color Circuitry, Part 3, by Bob Dargan and Sam Marshall	8
Analysis of horizontal linearity, focus, convergence and high voltage rectifier circuitry operation.	
High Voltage Problems, by Paul Goldberg (A Work Bench Feature)	13
Problems in servicing high voltage circuitry.	
Tape Recorder Servicing Series, Part 1, by Robert Blanchard	14
Considerations in servicing an RCA push-button tape recorder.	
True and False Color Concepts, by Matthew Mandl	18
A distillation of the rumor, fact and fancy regarding competent servicing of color TV circuitry.	
A Special Purpose Tube Tester, by Jacob Anthes	22
Discussion of a simple, compact, easy-to-use tester designed primarily for TV tubes.	
A New License Bill, by Abraham Frankel	24
The LaFauci bill, now under enactment, may require the TV serviceman to be examined and licensed by the state. A discussion of the salient points of the bill and how they may affect the serviceman.	
Sell and Service Radio-Controlled Garage Door Operators, by San D'Arcy	33
An ingenious probe into the market of radio-controlled domestic appliances.	

CIRCUIT AND SERVICE FORUM

Answer Man	
Condenser Checker	13
H.O.T. Whistle	13
Selenium Rectifiers	43
The Work Bench—High Voltage Problems	
Admiral 21B1: No Brightness	20
Capehart CX33: Intermittent Blooming	20
Philco 1954 "B" TV181: 1B3's Burn Out	21
Westinghouse, Ch. 21050-01: No Raster	21
Rider TV Field Manual Service Data Sheets	
Hoffman, Ch. 400 21 Models 21M721, 21B723, 21M722; Ch. 401, 21 Models 21M146, 21B147, 21P148, 21M320, 21B321, 21P322	25
Maestic, Series 112-17", 113-21"	27
Video Speed Servicing Systems	
DuMont Chassis No. RA-166	29
Kaye-Halbert Model No. 231	31

DEPARTMENTS

Editorial	4	Trade Flashes	39
Answer Man	13	Association News	41
The Work Bench	20	Trade Lit Check List	45
New Products	36	Advertising Index	48

RADIO-TELEVISION SERVICE DEALER is published monthly by Cowan Pub. Corp., 67 West 44th St., New York 36, N. Y. Subscription price: \$1 for 2 years in the United States, & U.S. Poss. Elsewhere \$1 per year additional. Single Copies 25c. Reentered as second class matter Sept. 25, 1950 at the Post Office at New York, N. Y. under the Act of Mar. 3, 1879. Copyright 1954, Cowan Publishing Corp.

POSTMASTER: SEND FORM 3579 TO RADIO-TELEVISION SERVICE DEALER, 67 WEST 44TH ST., NEW YORK 36, N. Y.



EDITORIAL...

by S. R. COWAN
PUBLISHER

COLOR-TV STATUS

An executive of RCA announced on June 5th that "all of the five thousand 15 inch color sets which were scheduled for production during 1954 have been shipped to dealers and the company will not make any more sets of this size." Thus, you have confirmation of our contention all along that color TV as we know it today is nothing to get excited about. Frankly, we believe that the technical problems of color TV set mass production are far from solved and it may be a long long time before someone comes up with the final answer.

The servicing profession must keep abreast of technical developments but we do not believe it is wise for any serviceman to waste a lot of time and energy studying and absorbing knowledge that is obsolete and of no practical value before he gets it. What will color TV set circuitry be like when it is perfected and ready for mass production? I don't know, and neither do the manufacturers themselves at this writing. Of course the big problem is the color tube, and it is a problem, believe me! For that reason I say again, and with all the force at my command, you fellows must be very astute in regard to the material you read relative to color TV. Don't be fooled by glamour articles and "window dressing" published in trade journals. Pretty pictures—fancy 4-color illustrations—and lots of meaningless words about the generalities and theory of color TV are not going to prepare you for what will eventually come to pass.

Our editorial staff has carefully subdued its natural desire to make an impression, via glamour, on our readers, whether they be servicemen or advertisers, about color television. It's too bad that our contemporaries have not done likewise. Some of the other journals have, as one expert put it, made such a hub-bub about color TV that is nothing more than wishful thinking, that they're doing the service profession an injustice. That reminds me of the old saying, "All is not gold that glitters."

INSTRUMENTS AND PROGRESS

During the past few years engineers have developed electronic tubes and circuitry to an amazing degree. But the zenith of their progress is still beyond distant horizons.

To radio-TV servicemen test instruments are such fundamental working tools, so basic and nec-

essary to a routine day's work, that often they are simply "taken for granted." Have you ever spent an idle moment or two reflecting upon the amount of research and development that has gone into the design of present-day tube checkers, multi-meters and 'scopes? Have you ever considered how many tube types today's tube checker will analyze—and how adaptable these instruments are, designed so that they will handle a multitude of new tube types that are still only in the design stage?

To me, personally, tube checkers are a very "touchy subject." I recall an editorial I wrote on tube checkers nearly 15 years ago. It caused a furor, because the idea was so radical, and it was opposed, at that time, even by some tube checker manufacturers. I stated then, and I proclaim even more emphatically today, that every service shop should have the finest, most modern and versatile tube checker available and that no service dealer should ever test a customer's tubes free of charge.

I always maintained that a service charge for tube checking was justified and that the income thus derived would not only offset the instrument's cost but would also provide extra income with which to purchase other instruments as needed. Today it is standard trade practice for service dealers to charge 10c per tube for testing tubes brought into the shop by set owners. The latter are perfectly satisfied with that arrangement. Soon, I hope, service shops will see the light as brought to them by tube checking, and will no longer offer free estimates on service jobs. Without being facetious, no doctor will diagnose your ills and give you a free quotation on the cure cost so why should service dealers?

In the final analysis—talking about test equipment—one other thing should be borne in mind when considering the purchase of any instrument nowadays. Remember that circuit complexity, close tolerances and critical voltages required in most of today's electronic apparatus make it mandatory for an instrument user to choose for himself the finest that can be obtained presently. Instruments that merely provide "almost accurate" readings are worse than none at all. Think about your instruments for a moment! Are they modern or obsolete? Do they work for or against you? If you're not sure of the answer, it will be worth your while to discuss this with your electronic parts distributor.

Can You afford to take a Chance

ON ANYTHING LESS THAN BUSS QUALITY IN FUSES?

Hardly!

Dependable electrical protection . . . isn't that what you rightly expect of a fuse? For you rely on the fuse alone to safeguard your equipment when there is trouble in the circuit — and just as important, a fuse should never give a "false alarm" by blowing needlessly.

To make sure of proper operation under all service conditions, every BUSS fuse normally used by the Electronic Industries is tested in a sensitive electronic device that rejects any fuse that is not properly constructed, correctly calibrated and right in all physical dimensions.

And there's no need to sacrifice quality on any type of fuse, for BUSS offers a complete line of fuses to the Electronic Industries: — standard type, dual-element (slow blowing), renewable and one-time types . . . in sizes from 1/500 ampere up.

And in sales and service — your customer doesn't question quality when you furnish BUSS fuses. The BUSS trademark and the BUSS reputation for 'trouble-free' fuses have been firmly established over the past 39 years by the millions and millions of installations for home, farm, and industry. So be doubly safe — protect your profits and your reputation — standardize on genuine BUSS fuses.

For more information mail this Coupon

FUSETRON

TRUSTWORTHY NAMES IN
ELECTRICAL PROTECTION

BUSS

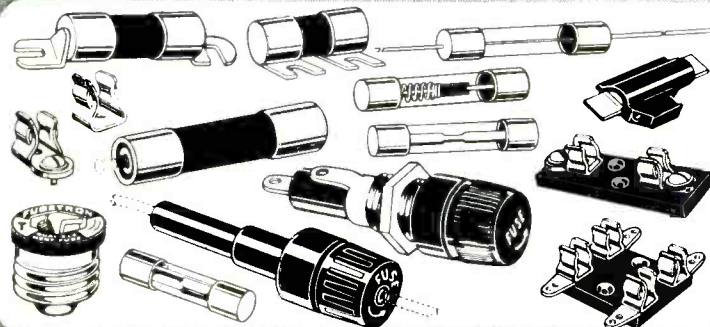

BUSSMANN Mfg. Co.
(Division of McGraw Electric Co.) SD-754
University at Jefferson, St. Louis 7, Mo.

Please send me bulletin SFB containing facts on
BUSS small dimension fuses and fuse holders.

Name _____

Title _____

Company _____

Address _____

City & Zone _____ State _____ 754

Free! HEAVY-DUTY TOP-QUALITY PLIERS KIT

with 10 CBS-Hytron Pliers Kit Stamps

LIMITED OFFER

From July 1 through August 31 . . . Your CBS-Hytron distributor will give you 1 Pliers Kit Stamp with your purchase of 25 CBS-Hytron receiving tubes.

A
\$ **10⁰⁰**
LIST VALUE



PICK UP THESE FINE IMPORTED TOOLS. Examine the beautiful finish of their drop-forged tool steel. Try their comfortable handle grips. Feel the precise balance . . . the powerful leverage. Go ahead! Cut some eight-penny nails. Like cutting cheese, wasn't it? And not a trace of a nick in the tough, carefully matched jaws.

You will be proud to own these husky, quality pliers. Tested . . . guaranteed . . . they can take it. And did you notice that two are unique? Nothing else just like them . . . they are "musts" for your tool kit. Yes sir, this free Pliers Kit (packed in an attractive, handy plastic case) is an offer you cannot afford to miss!



The 6½-Inch Diagonals are husky, box-joint, fully polished side cutters with precisely matched jaws. Size is right: Compact, but big enough . . . with comfortable, full-fashioned, full-polished handles . . . to do repeated, tough cutting jobs with ease.



The 8-Inch Long-Nose is unique. Extra-long (2¾ inches), spring-tempered jaws combine with extra-long, knurled handles for powerful leverage. Beautifully chrome-plated.



The 6-Inch All-Purpose is also unique. Combines: Flat and round nose. Jaws shaped for positive gripping. Two wire strippers. Two side cutters. Finish of handles is gun-metal; jaws are fully polished. This tool has everything.



Get This Pliers Kit Stamp Book . . .

and stamps from your CBS-Hytron distributor: One Pliers Kit Stamp for 25 CBS-Hytron receiving tubes. Each Stamp is imprinted with *your* CBS-Hytron distributor's code number. Redeem your Stamps with him. This offer is valid only in areas where such offers are legal . . . and it is limited: July 1 through August 31. Don't miss it. Be sure to get *your* free CBS-Hytron Pliers Kit. See it at your CBS-Hytron distributor's . . . today!

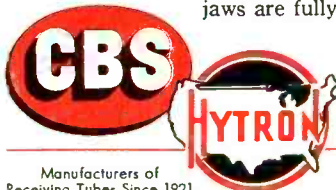

CBS-HYTRON Main Office: Danvers, Mass.

Manufacturers of Receiving Tubes Since 1921

A Division of Columbia Broadcasting System, Inc.

A member of the CBS family: CBS Radio • CBS Television • Columbia Records, Inc. • CBS Laboratories • CBS-Columbia • CBS International • and CBS-Hytron

RECEIVING • TRANSMITTING • SPECIAL-PURPOSE • TV PICTURE TUBES • CRYSTAL DIODES AND TRANSISTORS

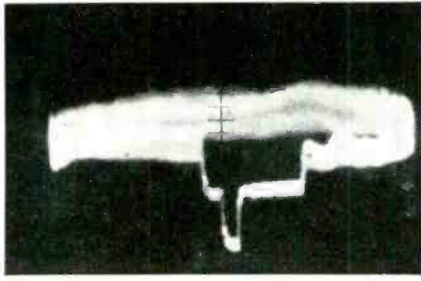

Fig. 1 — Vertical sync pulse.

Q. When I use a crystal demodulator probe to signal trace the *if* amplifier, the vertical sync pulse appears stripped, with the equalizing pulses removed, and the serrations in the vertical sync pulse missing. What is the explanation for these distortions?

A. This situation is illustrated in Fig. 1. It is caused by the limited frequency response of the demodulator probe, which filters out the higher-frequency components of the video

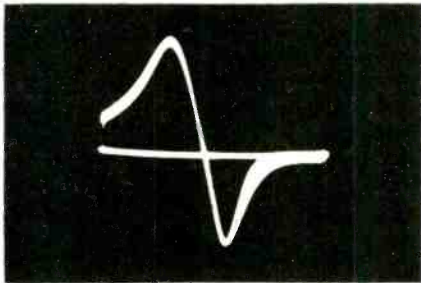

Fig. 2 — Ratio detector "S" curve.

waveform. However, this is not a matter for concern, since the operator is primarily concerned with localizing a dead or weak *if* stage.

Q. When sweep-aligning ratio detectors, the 4.5-*mc* marker indication usually appears much more prominent at the ends of the S curve than in the center portion. Is this normal?

A. Yes. Ratio detectors, unlike discriminators, have a high degree of AM rejection, which complicates the marking problem, as shown in Fig. 2. It is often helpful to modulate the marker, and adjust the ratio-detector transformer for minimum "wiggle" in the base line of the pattern.

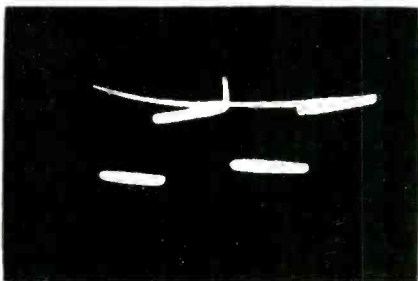

Fig. 3 — Overshoot as seen on scope.

TV INSTRUMENT CLINIC

PART 3

Based on *CHALLENGE CLINIC* demonstrations, this new series discusses many measurement and test problems raised by service technicians.

by **ROBERT G. MIDDLETON**

Field Engineer,
Simpson Electric Co.

Q. What is meant by overshoot and ringing in square-wave response, such as when a 60-cycle square-wave check is made of the video amplifier in a receiver?

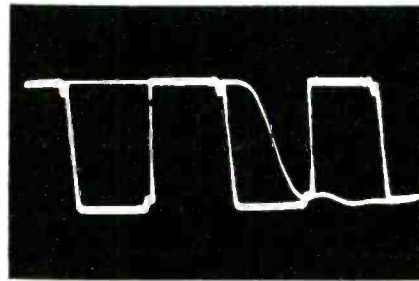

Fig. 4 — Ringing as seen on scope.

A. Overshoot is illustrated in Fig. 3, and ringing is illustrated in Fig. 4. Overshoot consists of an initial abnormal circuit response, immediately followed by the steady-state condition. Ringing consists of electrical echoes in the circuit. In some cases, an overshoot is followed by a ringing condition.

Q. What does tilt look like in a reproduced square wave?

A. A typical tilt response is shown in Fig. 5. Tilt is the result of phase shift in the circuits under test.

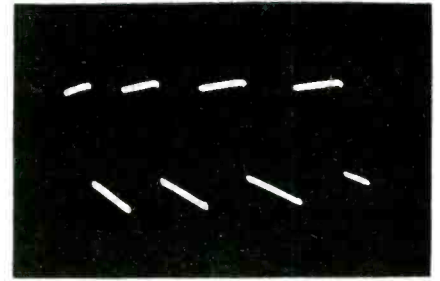

Fig. 5 — Tilted response pattern.

Q. Do rounded corners in a reproduced square wave always indicate the presence of frequency distortion, i.e., high-frequency attenuation?

A. Rounded corners indicate high-frequency attenuation, if all corners are rounded. However, if diagonal corners are rounded, as shown in Fig. 6, it is indicated that phase shift is occurring at high frequencies.

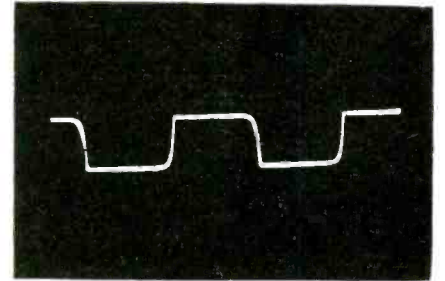

Fig. 6 — High Freq. phase shift.

Q. Why is it that a reproduced square wave with rounded corners appears to have a better shape when the vertical-gain control of the scope is increased?

A. This situation, which is illustrated in Figs. 7 and 8, is the result of a psychological illusion. By increasing the proportion of height to width, it would appear that the rise time of the waveform is improved, although the rise time actually remains constant.

Q. What causes a scope pattern to jitter?

[Continued on page 38]

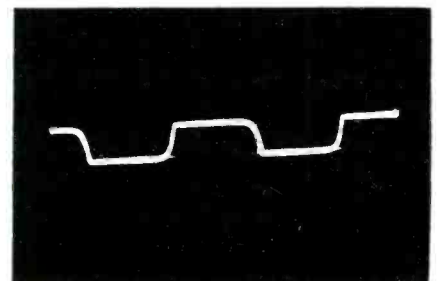

Fig. 7 — Vertical gain reduced.

Horizontal and High Voltage

By **BOB DARGAN** and **SAM MARSHALL**

From a forthcoming book entitled
"Fundamentals of Color Television."

Horizontal Linearity

The horizontal linearity coil in the plate circuit of the damper tube (Figs. 15 and 16) is effectively a wave shaping network which provides a means of varying the waveform of conduction in the damper tube. Such waveform variations are shown in Fig. 18. Adjusting the core of the coil, and thereby its reactance, alters the impedance characteristics of the linearity network, producing the waveform variations shown.

When the shape of the current waveform through the deflection coils is changed, the horizontal linearity of the picture is altered. Since damper tube conduction occurs immediately after retrace, when the beam is at the left side of the picture, it is this portion of the sweep that is affected by the horizontal linearity coil adjustment. With refer-

ence to Fig. 15 it will be observed that the primary and secondary windings of the linearity coil, which are bifilar wound, are connected in series aiding through C_1 , a 25 μf condenser. This condenser provides an ac short circuit for the pulses that appear at this point. This type of circuit permits a high value of inductive reactance to be obtained between the horizontal deflection coils and the B+ point, the latter being effectively grounded through the filter condensers of the power supply. Unless this isolation is effected the horizontal pulses would be grounded.

In accordance with the reasons outlined in the previous paragraph, Points A and C in Fig. 15 must be effectively isolated from B+. Notice that the horizontal centering control is connected directly to point A. Since the current through this centering control is ob-

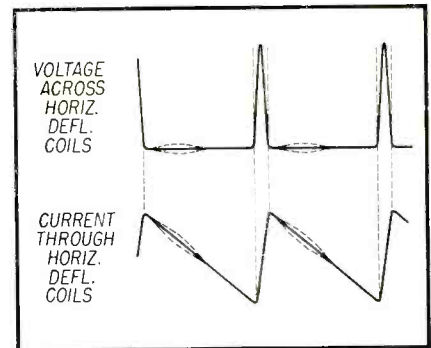

Fig. 18 — The horizontal linearity coil produces variations in the waveforms of current and voltage of the horizontal deflection coils as shown with the dashed lines.

tained from the "B" supply, some means must be provided which will provide a high impedance between the centering control and the B+ line. In the circuit arrangement shown this function is performed by the horizontal linearity coil.

Notice that two 25 μf condensers, C_2 and C_3 are used in conjunction with the centering control. These condensers are provided to short-circuit the horizontal pulses around the control.

The Focus Circuit

High voltage for focusing is developed from a special winding on the horizontal output transformer which applies a positive spike voltage of more than 4,000 volts to the focus high voltage rectifier tube. This rectifier may be either a 1X2A, 3A2, 3A3 or their equivalent. The spike voltage is rectified by the tube and 4,000 volts dc is made available as shown in Fig. 19. The focus voltage is obtained from the variable arm of a 5 megohm potentiometer and applied through a winding on the convergence transformer to the focus anode of the picture tube. Focusing is effected

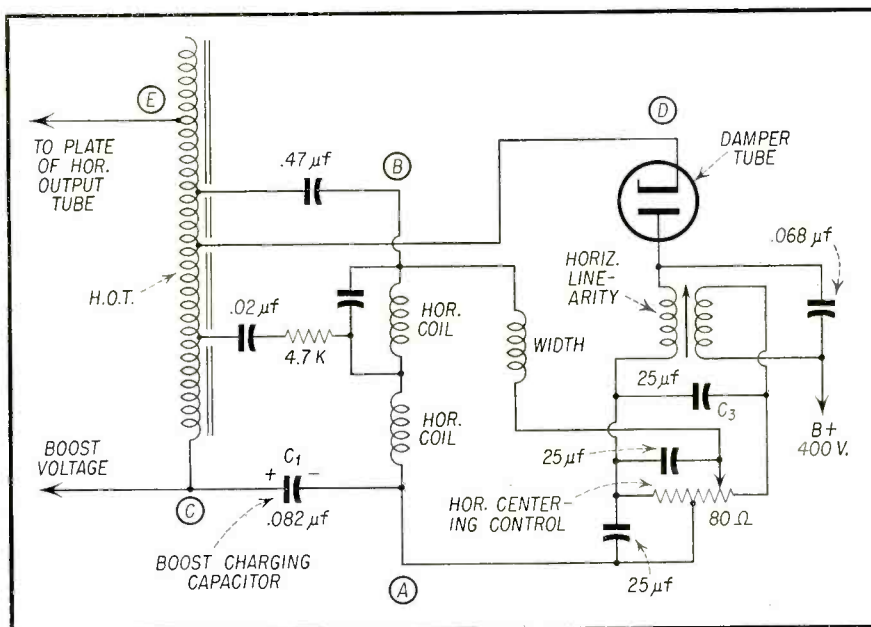

Fig. 15 — Partial schematic of a damper circuit in a typical color receiver.

Color Circuitry

PART 3

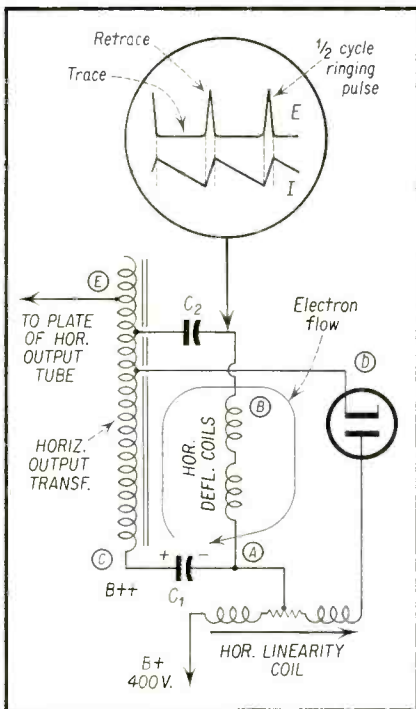

Fig. 16 — Current and voltage waveforms in a deflection system. The condenser, C_1 , has electrons removed from the side marked (+), thereby making this side of the condenser positive, which becomes $B++$.

by means of a 1500 μf filter condenser connected at the cathode of the rectifier tube.

Convergence

One of the new circuits employed in color TV involves converging (bringing to a point) the three color beams at the plane of the picture tube's shadow mask. In this manner the beams will strike the proper phosphors on the face of the picture tube after passing through the holes of the shadow mask plate.

Two types of convergence are asso-

ciated with this operation. The first, which is static convergence, has to do with obtaining convergence about a fairly large area around the center of the tube, and requires certain correct dc potentials between grid #4 (converging electrode which is common to all guns) and the high voltage applied to the ultor.

If the guns were positioned perfectly, correct, static convergence would be obtained. However, due to manufacturing variations perfect alignment is not obtained. To effect correct static convergence three alnico magnets are positioned 120 degrees with respect to each other around the periphery of the neck of the tube, and near the electron guns. By correctly positioning these magnets and the application of correct voltages between grid #4 and the ultor, correct convergence of the three color beams is obtained. Approximate values of convergence voltage vary between 8,500

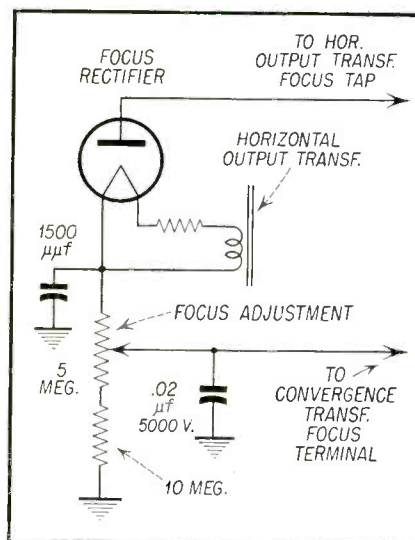

Fig. 19 — Color TV focusing system.

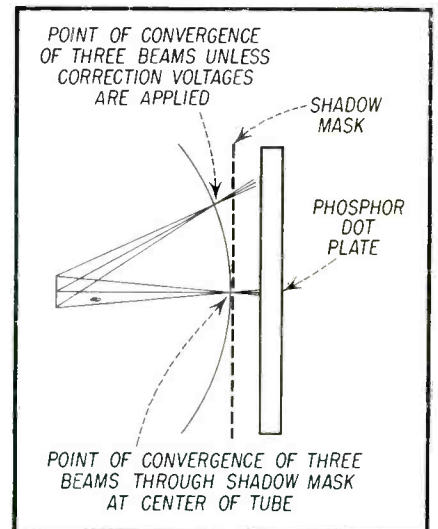

Fig. 20 — This shows the need for correction voltages to cause the three beams to converge through the shadow mask holes over the whole face of the color tube.

and 11,000 volts (maximum). The dc current that flows in the converging electrode is very small.

Up to this point convergence has been considered around a broad center area of the tube. As the beam is swept away from the center it must travel a greater distance before it reaches the shadow mask and phosphor dot screen as shown in Fig. 20. This results in a premature divergence of the three beams unless a correction voltage is added to the static convergence voltage. How this correction voltage is applied is discussed in the section on "Dynamic Convergence" in a subsequent chapter.

High Voltage Rectifier Circuit

Aside from increased voltage, current, and better voltage regulation, high voltage circuits used in color television receivers are similar to those used in black

LOOK TO THE LITTLE INDIAN  FOR

THE **BIGGEST** VALUE IN

MOLDED PAPER TUBULAR CAPACITORS

the Sangamo

Telechief®



The Telechief will outlive all other tubulars! Major manufacturers' test and stamp of approval prove that

Telechiefs have longer life. They have a final insulation resistance value 10 to 15 times greater than any other paper tubular—because they're molded in HUMIDITITE!



The Telechief outperforms all other molded paper tubulars in moisture resistance... in high temperature operation... in holding its rated capacity under all conditions.



EXTRA VALUE AT NO EXTRA COST! This amazing new capacitor—that meets specifications so tough that no previously existing paper tubular could approach them—is a *premium* tubular at the price of an ordinary one. See your Sangamo Distributor today!



SANGAMO ELECTRIC COMPANY

MARION, ILLINOIS

SC 54-11

and white receivers. The output of the high voltage tap on the H.O.T. used in color is about 10 KV. Application of this initial 10 KV pulse to the plate of the first high voltage rectifier diode causes it to conduct. The electron flow in the cathode circuit charges up the condenser C1 (Fig. 21) to about the peak value of the pulse, the positive charge appearing on the cathode side of the condenser.

The voltage on C1 is now applied to the plate of the tube V2. In between sync pulses the negative plate of C2 is

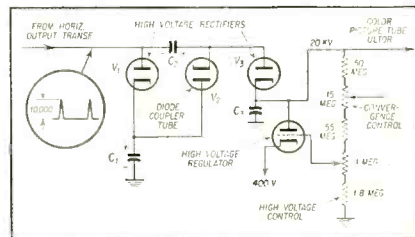

Fig. 21 — The high voltage rectifier system.

effectively grounded through the horizontal output transformer. Condenser C2 is therefore charged through the electron path provided by V2. This is shown more clearly in the equivalent diagram of Fig. 22. By a series of in-

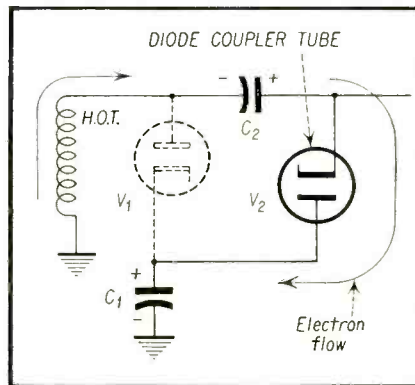

Fig. 22 — The negative electrons are caused to flow through the tube V2 by the potential built up across C1. At this time the condenser C1, H.O.T., condenser C2 and tube V2 are in series and condenser C2 is thereby charged to the polarity shown by the potential across C1.

cremental pulse charges C1 and C2 eventually charge up to the full 10 KV pulse voltage applied initially, with the polarities indicated in the figure.

V2 actually takes the place of the two meg resistors used in conventional high voltage doubler systems of black and white receivers and is presently referred to as a "diode coupler." Its fila-

[Continued on page 44]

The BACKSTOP

STOPS co-channel and adjacent-channel interference caused by rear signal pick-up!

- Highest front-to-back ratio ever built into an antenna!
- No rear pick-up; eliminates "venetian blinds"!
- Largest screen area: 70 square feet!
- Very high all-channel gain. Incorporates basic Champion design, including Tri-Pole, with additional elements!
- Completely preassembled!

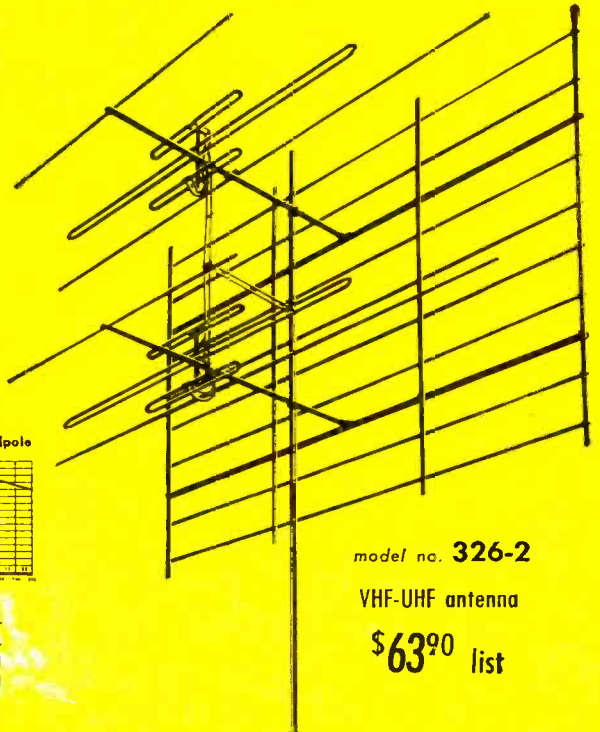
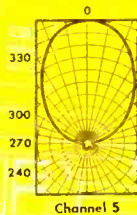

Table of Front-to-Back Ratios (Relative Voltage)

Channels	Front-to-Back Ratios
2	9:1
3	10:1
4	11:1
5	20:1
6	18:1

Only Low Band channels shown, since co-channel interference is not encountered on High Band channels.



Channel 5

Gain Above Tuned Reference Dipole



IMPORTANT ... don't be misled by polar patterns representing relative PCWER. Remember, power is the square of voltage. All Channel Master polar patterns are presented in relative VOLTAGE.

model no. 326-2

VHF-UHF antenna

\$63⁹⁰ list

2 radical new antennas by CHANNEL MASTER

The most beautiful antenna ever made! The only indoor antenna featuring powerful outdoor design principles — Bow-Tie and Screen.

Wonder Bow

* VHF-UHF indoor antenna

DESIGNED FOR POWER!

On **UHF**: For primary and secondary areas. In many cases, performance is equal to actual outdoor installations. Good directivity on all channels.

On **VHF**: Ideal in areas of strong VHF signals.

STYLED FOR BEAUTY!

Designed by a well-known industrial designer, the WONDER BOW is proof that indoor antennas can be beautiful as well as powerful. Wins customer approval on beauty alone!

The first gain figures ever to be published for an indoor antenna!

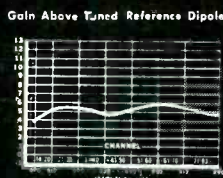

Gold and black

model no. 416

Silver and black

model no. 417

\$835 list

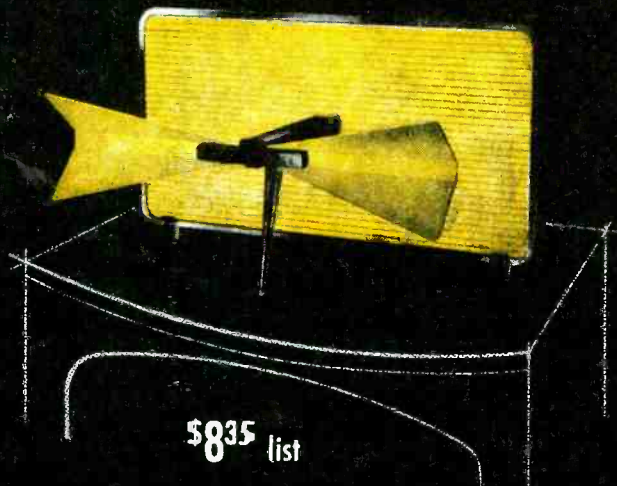

CHANNEL MASTER CORP. 111 NY PLAZA, N. Y.

The World's Largest Manufacturer of TV Antennas

Write for complete technical literature.

Copyright 1954, Channel Master Corp.

*Pat. No. D-171560

A look inside will show you why—

CROSLEY SUPER-V IS A SERVICE MAN'S DREAM

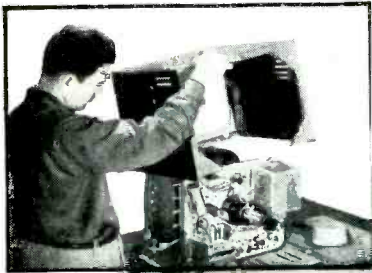

- Bonnet-type cabinet lifts right off
- No more chassis tugging
- Every tube accessible at rear

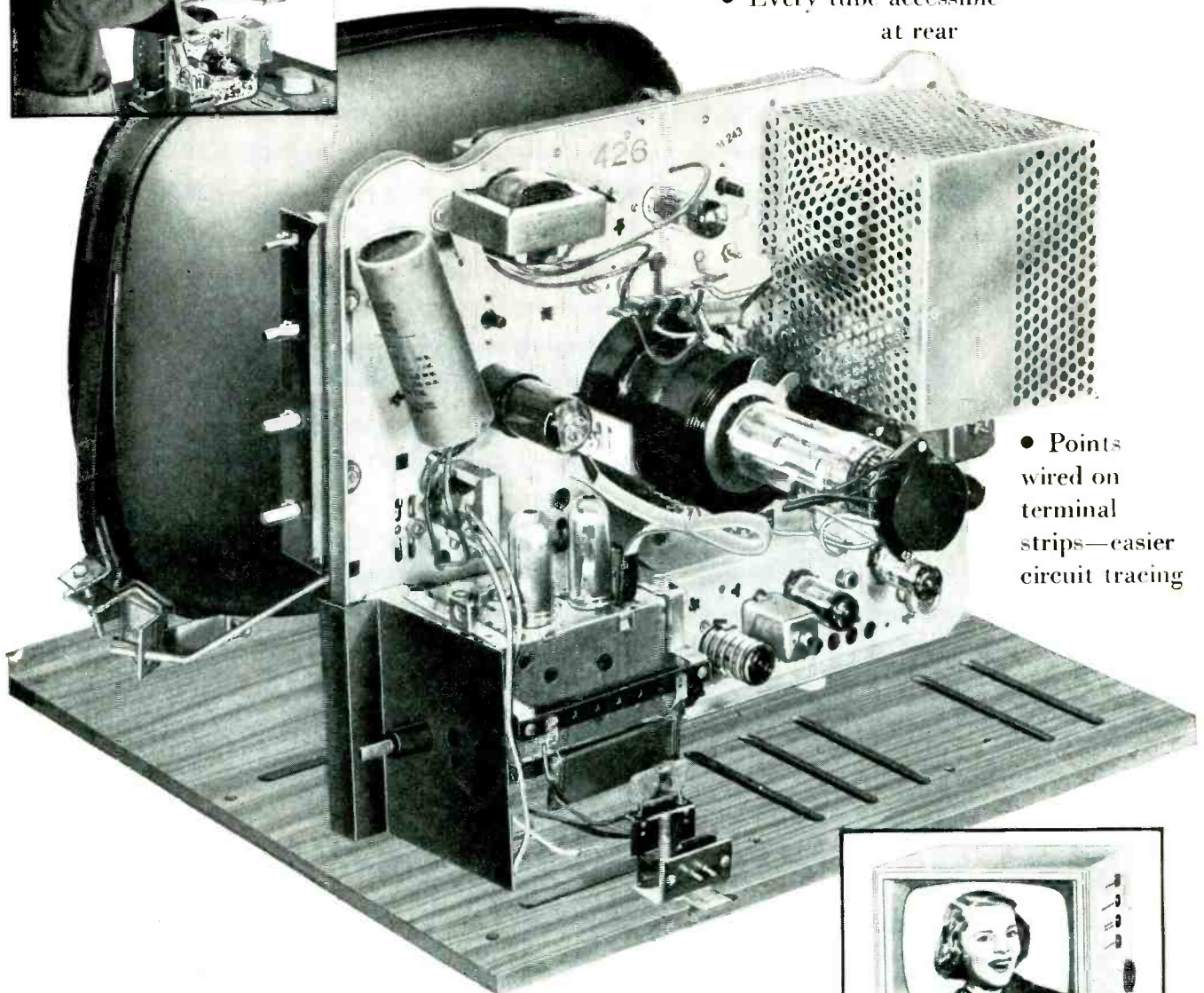

- Points wired on terminal strips—easier circuit tracing



Everything about this exciting new TV set was planned and built with you in mind! Crosley's own revolutionary vertical circuit makes checkups simpler than ever. Changing a tube takes only a few minutes (they're all at the back

in easy reach) and more complicated service requires only the loosening of 6 screws; lifting the entire cabinet off. Men who've serviced the Super-V call it the greatest forward step in TV chassis design.

Crosley Division  Cincinnati 25, Ohio



"The Answer Man"

by **BOB DARGAN**

Do you have a vexing problem on the repair of some radio or TV set? If so, send it in to the Answer Man, care of this magazine. All inquiries acknowledged and answered.

Condenser Checkers

Dear Answer Man:

I am very interested in your opinion on condenser checkers. Many condensers that become defective do not leak sufficiently to show a measurable voltage drop across the plate load resistor when the tube is removed. I am thinking of purchasing a condenser checker and would like to know your reaction to them.

L. E.
Harrisburg, Pa.

Measuring Leaky Condensers

Dear L. E.:

As you mention in your letter, a convenient method of checking condensers for leakage is to measure the voltage drop across the series resistor when the tube in the circuit is removed as shown in Fig. 1 and Fig. 2.

In Fig. 2 if the coupling condenser is leaking electrons will flow around the path indicated. It may be more advantageous to measure the voltage drop across the grid leak resistor than across the plate load resistor. The grid leak resistor, being usually much larger in resistance value, will have the same leakage current flowing through it as through the plate load resistor and will develop a larger voltage drop across it.

For a more conclusive indication the plate load resistor should be shorted out. This will cause the full voltage to be applied to the condenser and grid leak resistor. In this case the tube in the grid leak resistor circuit must be removed because the positive leakage voltage applied to the grid will cause it to draw current. This, in turn, usually

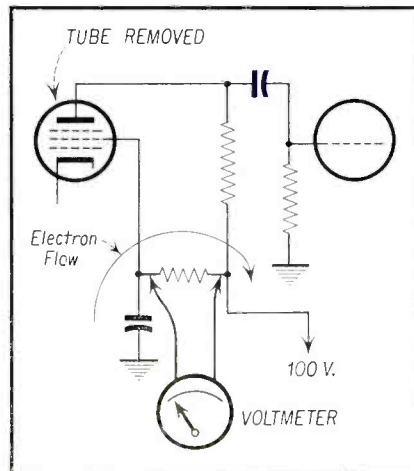

Fig. 1 — Leaky screen cap. will show up as a reading across meter if the tube is removed.

reduces the voltage drop across the grid leak down to a very small value.

This method will reveal the current leakage through condensers provided the leakage is sufficient to develop a measurable voltage drop across the grid resistor. Checking of this type can avoid a considerable amount of clipping of condensers.

However, checking across the tube load is not feasible in many cases such as in the *if* and tuner stages. In particular, where sync stages are concerned, a small leak in a *dc* blocking condenser which may not be measurable by the above methods may cause sync clipping with a resultant picture pull or sync trouble.

One of the answers to the problem of checking condensers is the condenser checker. These relative inexpensive units permit quick measurements of

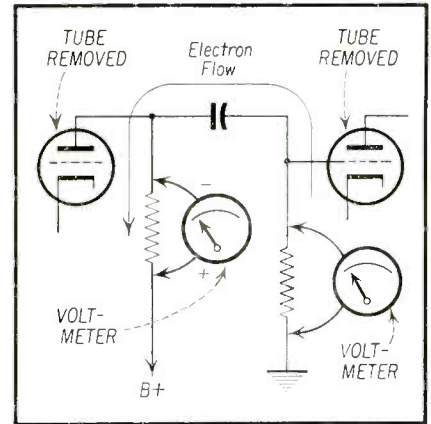

Fig. 2 — Leaky coupling condenser leakage measurement.

capacitance values and current leakage. It is only necessary to clip one lead of the condenser to be tested and make the connection of the two clip leads from the condenser checker to the condenser pigtailed. Capacitance values and leakage can then easily be measured. In many cases this leakage may only be determined with a condenser checker or by substitution of a test condenser.

One of the advantages of a good condenser checker is that it generally furnishes up to 450 volts *dc* for leakage tests. Thus, these checkers will show the leakage under actual voltage conditions.

H. O. T. Whistle

Dear Answer Man:

I have a TV receiver that has a loud horizontal output transformer high pitched whistle. What can I do to eliminate this condition?

G. D.
Philadelphia, Pa.

Dear D. G.:

A whistle or high pitched sound ascertained to come from the horizontal output stage may originate in the horizontal output and damper tubes; in the width coil if one is used; but most frequently comes from the horizontal output transformer. The whistle usually results because some part is loose enough to vibrate mechanically at the horizontal deflection frequency.

Naturally the first items to check in the servicing procedure are the horizontal output and damper tubes. A loose core in the width coil has been known to cause this annoyance. This can be eliminated by inserting a small piece of fish paper between the coil form and the core. An adjustment of the width may in many cases also eliminate this condition.

With reference to the transformer, shock mounting this component will
[Continued on page 43]

Tape Recorder



Complete servicing procedure covering the popular RCA SRT-301 tape recorder is given in this article. The same treatment covering other makes will appear in subsequent issues.

MARKET surveys, research and sales figures reveal the interesting fact that magnetic tape recorders are being bought and used in the home by the same people who buy and use radios, record players, and TV sets. Of the 300,000 tape recorders sold in 1953, estimates are that approximately 65% or 195,000 were sold specifically for use in the home. It is only natural that these owners of tape recorders should look to the radio and TV service dealers for help when the tape recording equipment is in need of repair. Servicing and adjusting the popular RCA Push-Button Tape Recorder, Model SRT-301, is explained here and illustrated in detail.

Tape Data

The tape used is standard 1/4" magnetic tape oxide coated, plastic base, wound on reels with coated side in. Tape capacity is a maximum of 1200 ft. on a 7-inch reel. Tape speed is 3 3/4" and 7 1/2" per second.

ADJUSTMENTS

Record-Play Head Adjustment

To adjust the head (item 24, Fig. 2) for maximum frequency response, make the following adjustments:

1. Remove the rear escutcheon (item 5, Fig. 7) by removing the single screw which can be seen holding it in place at the point closest to the SPEED change knob.

2. Properly thread an alignment tape, if one is available. If such a tape is not available, a well recorded tape containing music with wide frequency response will do.

3. Turn the VOL control to the "on" position and allow 30 seconds for the tubes to warm up. Depress the PLAY button until it is latched into position.

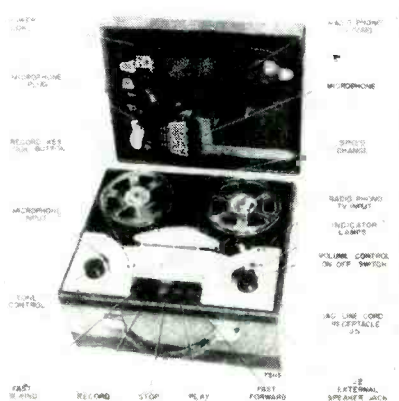

Fig. 1 — Identification of components with lid of unit opened.

Adjust the VOL control for a suitable sound level with the TONE control at its extreme clockwise position.

4. Grip the vertical portion of the record-play head mounting bracket with a pair of long-nosed pliers. Slowly rock the mounting bracket and the head from side to side very slightly. Notice that as the head is rocked to either side a "tone control effect" occurs.

5. At one point as the head is rocked it will be observed that maximum high frequency response is obtained. Bend the bracket with the pliers to obtain a permanent "set" at this position.
6. Replace the rear escutcheon.

Pressure Pad Adjustment

1. For this adjustment both the front and rear escutcheons must be removed.
2. Depress the PLAY button. Do not turn the recorder "on."

3. Using a pencil type postal scale secured or hooked to the end of the pressure pad mounting spring (item 33, Fig. 2 and Fig. 7), check the amount of pressure necessary to just pull the pad from the tape.

4. Optimum pressure of the pad occurs at a reading of 1 3/4 ounces \pm 1/4 ounce. The record-play head pressure pad is adjusted by the adjustment screw (item 40, Fig. 2 and Fig. 7). Unlocking and rotating this screw clockwise increases pressure. Unlocking and rotating this screw counter-clockwise decreases pressure. Be sure to relock the screw after completing this adjustment.

5. The guide post pressure pad (item 39, Fig. 2 and Fig. 7) must be adjusted for minimum pressure against the tape. This adjustment is made by bending the pressure pad spring in or out with a pair of long-nosed pliers.

6. After the pressure pad adjustments have been made, depress the STOP button and replace the front and rear escutcheons.

Erase Head Adjustment

1. With both escutcheons removed, thread a reel of tape, turn the recorder "on" and depress the RECORD button.

2. Allow the tape to run for a few seconds and then turn the recorder "off," but leave the RECORD button depressed.

3. Looking down on the top panel of the recorder, check the erase head

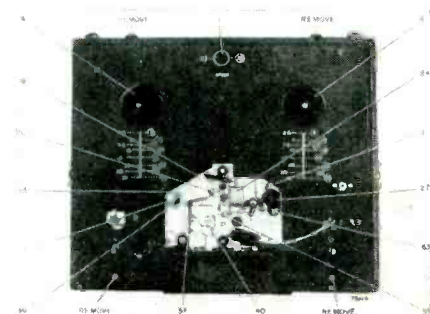

Fig. 2 — Parts shown in this view may be checked in Parts List.

Servicing Series

ROBERT BLANCHARD
RCA, Camden, N. J.

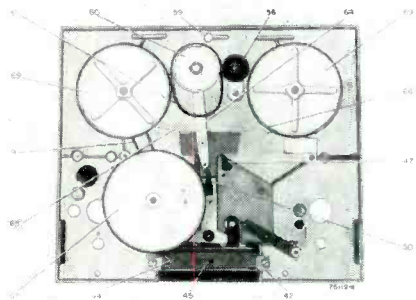

Fig. 3 — Bottom view of tape recorder showing flywheel, brake drum and shaft, idler lever assembly, idler tension spring, take-up reel drive belt, sub idler rubber tire pulley, etc.

(item 113, Fig. 2 and Fig. 7) to see if it is parallel with the tape. If it is not, loosen the retaining screw (item 19, Fig. 2) just enough so that the head can be pivoted into a parallel position and then retighten the screw.

4. Look at the tape and the erase head from the forward view to determine if the top edge of the tape coincides with the top end of the diagonal slot in the erase head. If they are not coincident, correction is made by adjusting the level of the tape. To do this, loosen the lock nut (item 17, Fig. 2) atop the tape guide post and rotate the guide post to move the tape up or down. Tighten the lock nut.

5. After this adjustment has been made, depress the RECORD key and observe whether or not the tape moves forward approximately 1/64". If not, loosen the forward adjustment screw (item 20, Fig. 2) and turn the screw in or out as required to obtain this 1/64" adjustment. Tighten the lock nut on item 20.

6. Replace the front and rear escutcheons when the above adjustments are completed.

Brake Pad Adjustment

1. In order to adjust the brake shoes the complete mechanism must be removed from the carrying case as explained in "disassembling instructions."

2. With all push-buttons in the up position the brake pads should clear the drums (item 69, Fig. 4) by approximately 1/8".

3. Depress the STOP push-button while closely observing the brake pads. Both brake pads must contact the drums at the same time and with equal pressure.

4. The adjustment of timing and pressure is accomplished by bending the spring arm (item 65, Fig. 7).

Adjustment For Slow Take-Up Reel

Should it become apparent that the right hand reel is taking up tape slowly, evidenced by a sluggish or loose action when in the PLAY mode of operation, the indication is that the coil-spring drive belt (item 9, Fig. 3) has stretched. The tension of this coil-spring can be increased by shortening it. This is done by clipping off 3 to 5 turns of the coil.

Recording Bias Adjustment

The recording bias should need adjustment only if the input tube, type 5879, is replaced. The bias adjustment trimmer, C18, Fig. 6, is accessible when the recorder mechanism is removed from the cabinet and the amplifier chassis bottom cover is removed.

1. Turn the recorder "on" and depress the RECORD push-button.

2. Set the VOL control to minimum (counter-clockwise) without, of course, turning the power switch "off."

3. Connect an *ac vtvm* (must be low input capacity type output to 40 kc) to pin 21 on V3, the grid of the 6AQ5. Refer to Fig. 5.

4. Adjust trimmer C18 to obtain a meter reading of 2.25 volts.

Neon Recording Indicators

The neon recording level indicators should need adjustment only if one of the two neon bulbs is replaced. These are adjusted for correct firing level by

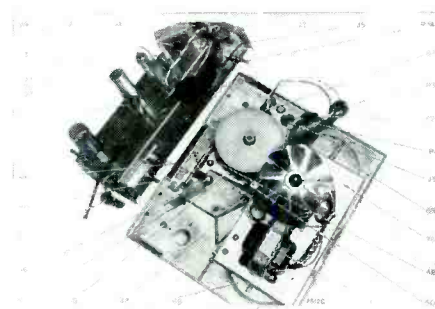

Fig. 4 — Another view of recorder and amplifier chassis showing locations of various components.

MECHANICAL PARTS LIST

Ref. No.	Description	Ref. No.	Description
1	Knob, speed shift	84	Fan, motor cooling
2	Screw, #0-32 x 1/4, binder head	85	Washer, lock
3	Lockwasher, #6 internal	86	Resistor, spring push on type
4	Reel shaft, left	87	Capacitor, motor shock mount
5	Escutcheon, rear	88	Clip, base post type
6	Screw, #0-32 x 1/4, binder head	89	Washer, linen (pkg. of 10)
7	Lockwasher, #6 internal	90	Lever, speed shift
8	Reel shaft, right	91	Brushing, idler slide
9	Reel, take up reel drive (spring)	92	Plate, idler pulley switch slide assem.
10	Knob, tone control	93	Spring, idler pulley tension
11	Escutcheon, front	94	Spring, idler pulley tension
12	Bracket, push button rear	95	Spring, idler lift helical
13	Button, push	96	Pulley, motor includes set screw #138
14	Screw, #0-32 x 3/4, R11	97	Screw, #0-32 x 1/4, R11
15	Knob, volume control	98	Lockwasher, #8 int.
16	Base plate	99	Washer, flat
17	Nut, #0-32 hex	100	Lever, idler throw out
18	Tape guide, left	101	Screw, #0-32 x 1/4, G31, Phil. Hd.
19	Screw, erase head adj. hex head self tapping	102	Washer, felt (knob)
20	Screw, erase head forward adj.	103	Washer, felt
21	Spacer, tape guide post (left)	104	Screw, #0-32 x 1/4, G31, Phil. Hd.
22	Nut, #0 hex	105	Washer, #8 int.
23	Tape guide, right	106	Lockwasher, #8 int.
24	Head, recording	107	Lockwasher, #8 int.
25	Clip, hairpin	108	Nut, #0-32 hex
26	Washer, linen	109	Washer, felt (knob)
27	Roller, pressure	110	Screw, #0-32 x 1/4, G31, Phil. Hd.
28	Washer, linen	111	Nut, #0-32 hex
29	Plate	112	Lockwasher
30	Spring, pressure roller tension	113	Head, erase
31	Lever, playback actuating	114	Lever, push button assem.
32	Plate, playback slide assem.	115	Washer, linen
33	Spring, pressure pad assem.	116	Washer, linen
34	Nut, speed	117	Nut, locknut for jack
35	Plate, record slide	118	Bracket, jack (top)
36	Plate, erase head	119	Jack, input
37	Spring, erase head tension	120	Screw, #0-32 x 1/4, R11
38	Lever, record counting	121	Lockwasher, #8
39	Pad, felt (part of #33 stock #9814)	122	Jack, phono (pkg. of 5)
40	Screw, spring adj. #0-32 x 1/4	123	Washer, #8 int.
41	Spring, push button return	124	Screw, set #0-32 x 1/4, Allen Hd. included with flywheel
42	Bracket, hinge for push button	125	Clip, hairpin
43	Screw, #0-32 x 1/4, Phillips Head	126	Washer, felt
44	Plate, push button locking	127	Screw, #8-32 shoulder screw hex head
45	Spring, lock plate	128	Lockwasher, #8 int.
46	Lever, amp switch	129	Lockwasher, #8 int.
47	Spring, brake return	130	Screw, #0-32 x 1/4, R11
48	Plate, brake slide	131	Screw, #0-32 x 1/4, R11
49	Spring, stop	132	Lockwasher, #8 int.
50	Spring, idler tension	133	C Washer
51	Plate, slip plate for high speed assem.	134	Screw, #0-32 x 1/4, Phillips Hd.
52	Spring, record interlock spring assem.	135	Clip, spring
53	Link, switch arm	136	Washer, linen
54	Base plate (same as 16)	137	Washer, shoulder
55	Spring, record interlock spring assem.	138	Screw, set #0-32 x 1/4, Allen Hd. (trapped with pulley)
56	Pulley, sub idler, rubber tire	139	Screw, set #0-32 x 1/4, R11
57	Washer, felt	140	Motor and trans. assem.
58	Clip, hairpin	141	Washer, flat
59	Slide, speed control	142	Screw, erase head adj. #0-32 x 1/4, R11
60	Pulley, idler drive	143	Screw, record head bracket #0-32 x 1/4, Phillips Hd.
61	Idler, idler drive (rubber)	144	Nut, part of stock #9808
62	Bracket, idler slide	145	Screw, #0-32 x 1/4, binder head
63	Idler, capstan, tape drive	146	Clip, E clip
64	Arm, brake	147	Button, press to operate record key
65	Pad, brake	148	Washer, flat
66	Flywheel	149	Clip, idler tension spring
67	Washer, linen	150	Screw, #0-32 x 1/4, R11
68	Throm brake drum and shaft		
69	Screw, #0-32 x 1/4, R11		
70	Plate, drive mounting		
71	Pulley, idler (rubber tire)		
72	Bracket, angle mounting		
73	Lockwasher, #8 int.		
74	Screw, #0-32 x 1/4, R11		
75	Plate, motor mounting		
76	Washer, motor mounting screw		
77	Lockwasher, #8 int.		
78	Screw, motor mounting #0-32 x 1/4		
79	Motor, drive		
80	Wing, E case for fan		
81	Washer, flat		
82	Washer, felt		
83	Washer, felt		

MISCELLANEOUS

Case, carrying case complete 1311" x 1311" x 1311" R11
Case, microphone front with screen mounted
Case, microphone back
Case, case lid
Clip, rubber fastener special
Handle, case carrying with two plates
Mechanism, microphone
Screw, shoulder, case inch long, 0-32 inch

Reference to the above Mechanical Parts List will help to identify the components shown in figures.

means of the 2 trimmer capacitors, C23 and C24, Figs. 5 and 6, one for each indicator. These trimmers are accessible after the recorder mechanism is removed from the cabinet and the amplifier chassis bottom cover is removed.

1. Turn the recorder "on" and depress the RECORD push-button.

2. Connect an audio oscillator and feed 1000 cycles into the MIC input jack. The output of the audio oscillator should be .01 volts. A 1 volt output level may be used with a 100 to 1 reduction pad of resistors inserted between the audio oscillator and the MIC jack.

3. Refer to Fig. 5 and connect the *vtvm* probe to the high side of the 3.3 ohms resistor, R25.

4. Adjust the VOL control to obtain a reading of .95 volts on the *vtvm*.

5. Adjust the "normal" indicator trimmer C23, refer to Figs. 5 and 6, fully clockwise and then turn slowly counterclockwise until the "normal" neon bulb barely lights.

6. Increase the VOL control to obtain a reading of 1.79 volts on the *vtvm*.

7. Adjust the "overload" indicator trimmer C24, Figs. 5 and 6, in the same

manner as C23 in step 25, until "overload" neon bulb just barely lights.

TROUBLE SHOOTING

Push-Buttons Fail To Latch Into Position

Lock plate spring (item 45, Fig. 3) loose or broken, resulting in the lock plate not being held against the hinge bracket (item 42, Fig. 3). Repair or replace.

Fails To Erase

1. Spring (item 37, Fig. 2) loose or broken, resulting in the erase head not being pulled forward to engage the tape. Tighten or replace.

2. Erase head not aligned properly. See "Erase Head Adjustment."

No Fast Forward Or Reverse

1. Idler lever tension spring (item 50, Fig. 3) may be loose or broken. If so, the idler lever (item 65, Fig. 3) will not be actuated. Tighten or replace tension spring.

2. Check idler drive belt (item 61, Fig. 3) to see if it is properly connected.

No Drive On Record Or Playback

1. Idler tension spring (item 93, Fig. 7) loose or broken and not holding idler wheel (item 72, Fig. 7) in engagement with motor pulley (item 96, Fig. 7) and fly wheel (item 67, Fig. 7).

2. Idler slide plate (item 92, Fig. 7) binding on the slide bushing (item 91, Fig. 7) and preventing the idler from moving forward.

Tape Fails to Wind on Reel During Record Or Playback

1. Reel drive spring (item 9, Figs. 2 and 3) loose or broken. Tighten or replace.

Speed Variation Or "WOW"

1. Refer to Figs. 2, 3, and 7. Check capstan (item 63), pressure roller (item 27), idler wheel (item 72), motor pulley (item 96), and fly wheel (item 67) for oil or foreign material. Clean the surfaces of these parts with a good cleaning fluid and dry thoroughly.

2. Check motor pulley (item 96) to see if it is secured to motor.

3. Check idler tension spring (item 93) to see if it is holding the idler engaged with the motor pulley and fly wheel.

4. Idler slide plate (item 92) may be binding on the slide pushing (item 91), preventing the idler wheel (item 76) from making positive contact with the motor pulley and the fly wheel.

Tape Overruns or Spills When Stop Button Is Depressed During Fast Forward Or Rewind

1. Brake shoes may be out of ad-

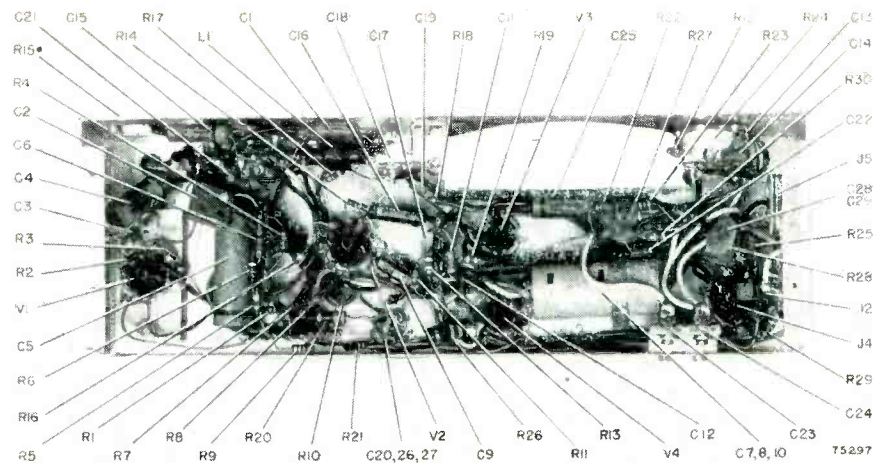

Fig. 5 — Bottom view of amplifier chassis showing locations of various components which may be identified by referring to Fig. 6.

justment. See "Brake Pad Adjustment."

2. Brake pads may be worn out. Replace pads.

Failure To Record

1. Tape pressure pad not adjusted properly, resulting in the tape not being held against the recording head. See "Pressure Pad Adjustment."

2. Record head loose on its mounting. Adjust head and tighten into position as described under "Record-Play Head Adjustment."

3. Check the recording tape to see if the dull coated side faces inward on the reel. If the dull side faces outward a recording can not be made. If this condition exists, rewind the tape onto an empty reel so that the dull side faces inward.

4. Check microphone connections at the plug and at the microphone.

Breaking Of Tape

Frequent breaking of the tape may be caused by either unequal pressure of brake pads or failure to depress the push-buttons firmly in a positive manner. Check for "Brake Pad Adjustment" and review "Operating Instructions."

CLEANING

The record-play head, capstan and pressure roller are, as with all tape recorders, subject to an accumulation of tape coating residue which is worn off the tape as it passes these parts. Use a soft cloth or cotton swabs and alcohol or carbon tetrachloride to clean the surfaces of those parts. *Caution:* Do not

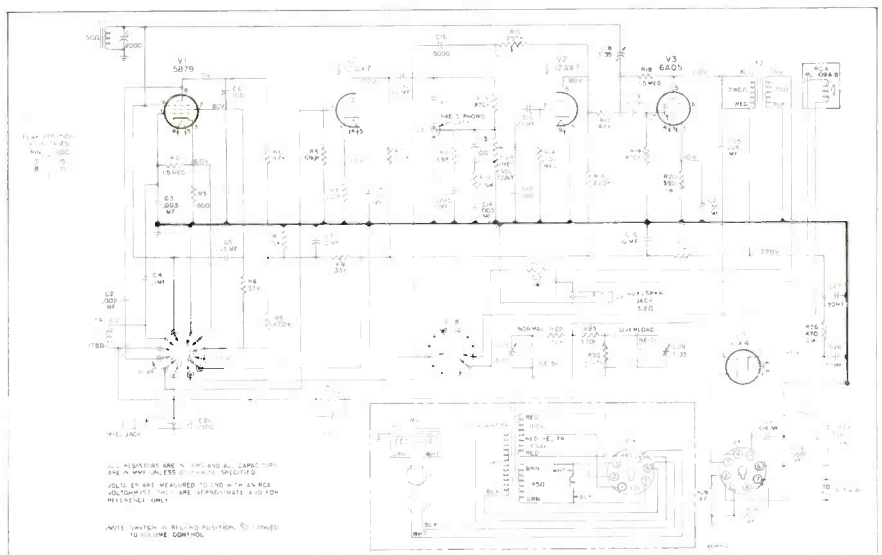

Fig. 6 — Circuit diagram of RCA Push Button Tape Recorder Model SRT-301. The input tube used is a 5879 type. This tube feeds a twin 12AX7 which in turn feeds a 6A05 output tube. The amplifier is powered by a transformer type of power supply using a 6X4 rectifier. The recording bias should need adjustment only if the input tube is replaced. Similarly the neon recording level indicators should need adjustment only if the neon bulbs are replaced.

use a brush when cleaning the recording head as this might mar the lamination.

LUBRICATION

All rotating parts are provided with generous size bearings which are factory lubricated and normally require no further attention. However, should lu-

brication be required, use a light grade of machine oil. A casual cleaning out of foreign matter under the plastic escutcheons is desirable. A small drop of oil on the sliding lever members of the push-buttons is advisable. *Caution:* Do not get oil on rubber parts or on any surfaces which contact the magnetic tape.

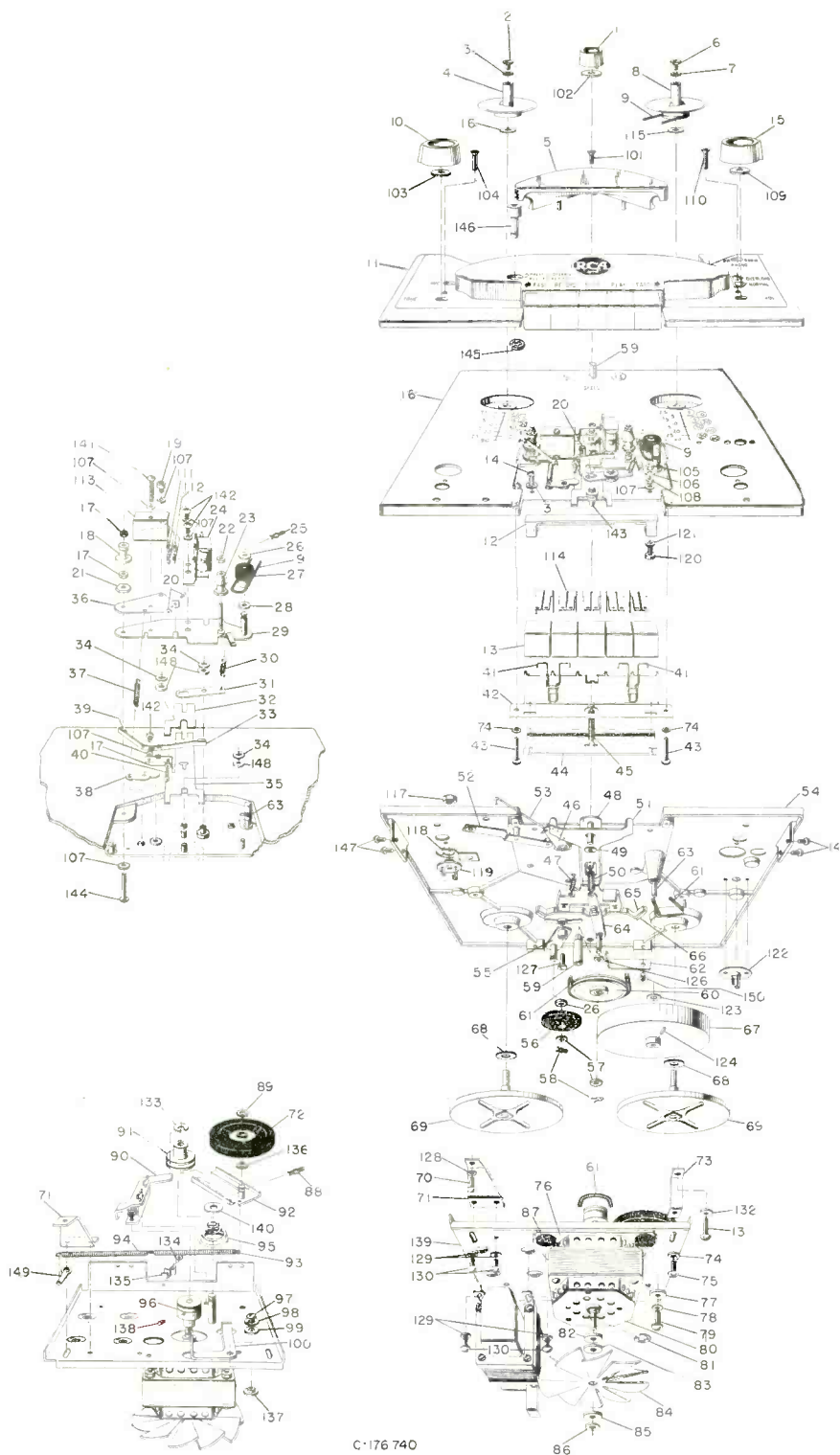

C-176 740

Fig. 7 — Exploded view of complete mechanism of RCA tape recorder. Components may be identified by referring to Mechanical Parts List.

4 NEW RIDER BOOKS RELEASED IN JUNE!

ADVANCED TELEVISION SERVICING TECHNIQUES

written by the RETMA (Radio Electronic Television Manufacturers Association) Pilot Training School Teaching Staff.

A completely new approach to books for TV service technicians. Written by experts who are teaching every day. The contents have been tried and proven to be the finest ever written. Completely practical. A step-by-step approach to how to service every section of a TV receiver with every kind of test equipment—by resistance measurement, by voltage measurement, by means of the scope. It explains the uses of test equipment of all kinds in connection with TV receiver servicing, such as sweep generators—signal generators—vacuum tube voltmeters—scopes, ohmmeters!

This is not a theory book! It is a book which every technician can use on the bench—and every student in a TV school can use, because it tells what to do and how to do it.

Never a book like this. Words alone cannot describe it. You have to see it to believe it! Approx. 175 (8½ x 11") pages. Soft cover. **\$3.60**

ATTENTION TEACHERS: The main book above and a Laboratory Manual for use with it, as well as the Teacher's Guide also are available. Write for details.

SPECIALIZED AUTO RADIO MANUALS

Cover 5 years production (1950 thru 1954) of factory installed car radios. Identical data from other sources is just not available! Each volume contains: Parts List, Schematics, Tube Layout, Voltages, Trimmer Location, Chassis Views, Chassis Pictures Dial Stringing, and complete installation and removal information.

VOL. 1-A (released in May) covers Ford . . . Lincoln . . . Mercury. Soft cover. **\$3.00**

VOL. 2-A covers Buick . . . Cadillac . . . Oldsmobile 200 (8½"x11") pages. Soft cover **\$3.00**

VOL. 3-A covers Chevrolet, Pontiac, GMC Trucks, Chevrolet Trucks. 128 (8½"x11") pages. Soft cover **\$1.80**

VOL. 4-A covers Chrysler, DeSoto, Dodge, Dodge Trucks, Plymouth. 160 (8½"x11") pages, soft cover **\$3.00**

COLOR TV DICTIONARY

by J. R. JOHNSON

First complete explanation of new color TV terms with their definitions that everyone—service technicians, students, engineers, amateurs—interested in color television must be familiar with. This is more than a dictionary! Over 50 illustrations. Approx. 72 (5½x8½") pages, soft cover. **\$1.25**

R-C & R-L TIME CONSTANT

edited by

ALEXANDER SCHURE, Ph.D., Ed.D.

FIRST IN A SERIES of review books written expressly for the student who is studying electronics or the technician who has studied electronics and wishes to understand Time Constant (R-C and R-L) more clearly. It supplements the contents of courses in textbooks which are on a technical institute level. Covers practical applications of Time Constant and how it affects circuit operation. About 48 (5½x8½") pages, soft cover. **\$1.90**

write for complete 32 page
NEW RIDER CATALOG

Buy these books now from your jobber, bookstore— if not available from these sources, write to:

Dept. SD7
JOHN F. RIDER PUBLISHER, INC.
480 Canal Street, New York 13, N. Y.

true and false -

COLOR CONCEPTS

By **MATTHEW MANDL**

Author of:
Mandl's Television Servicing

SINCE the advent of compatible color television, many servicing technicians have heard conflicting theories regarding the performance of color television receivers and servicing factors. In order to clarify some of the points which may still be puzzling the technician, the following material has been chosen as representative of the type of question uppermost in the minds of the service fraternity as they are called upon to service the more complex color television receivers. So that the various topics are cataloged in simple form, they are presented in the nature of true and false statements with an accompanying explanation which clarifies the problem.

Ghost reception is more noticeable when receiving color than for black and white:

True. The difference, however, is only to a slight degree. In tests undertaken by RCA, it was established that there is only approximately a few decibels difference. A pronounced and vivid ghost is objectionable on either black and white or color. A slightly discernible ghost, however, would be a little more noticeable on color reception be-



Fig. 1 — Ghost image on black and white screen. On color tube this image will be slightly more noticeable to observer.

cause of the color component of the ghost with respect to the primary image. See Fig. 1.

The horizontal and vertical hold controls will require frequent readjustment when switching from monochrome (black and white) to color transmission:

False. The vertical and horizontal sweep rates of color transmission are so close to those for black and white that no difference should be noted in horizontal stability when switching from one type of transmission to the other. For black and white, the horizontal sweep frequency is 15,750 cycles per second while for color it is 15,734.264. These horizontal sweep frequencies are so close to each other that if the horizontal system is operating properly either one will have no difficulty in locking in the horizontal oscillator promptly with rapid pulling and synchronization.

The same holds true for the vertical sweep frequency which in black and white is 60 cycles per second. For color transmission the vertical sweep rate is 59.94 cps, and again either frequency will produce immediate lock-in if the vertical system is operating properly.

When the color receiver ages and the vertical and horizontal circuit components change, the vertical and horizontal hold control ranges will be reduced, requiring frequent readjustment for stability in color and monochrome:

True. But only to the degree by which such controls would have to be adjusted in black and white receivers. The hold controls would have to have an extremely narrow range wherein stability is secured to make any difference between color synchronization and black and white synchronization. In weak signal areas the narrow range of the hold control would be a detriment. When this is the case, however, servicing adjustments are a necessity regardless of whether the receiver is in black and white or color.

Color is considerably more susceptible to random noise:

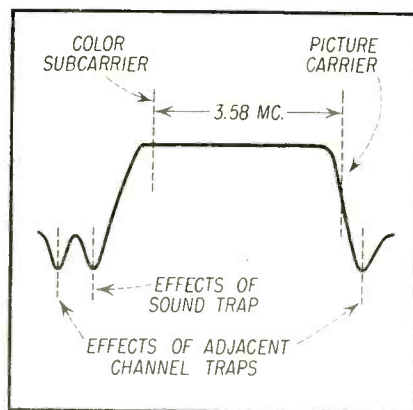

Fig. 2 — Sound and adjacent channel traps in color receivers produce more pronounced dips in an IF band-pass curve. Accurate trap adjustments are important.

False. It is true that there is a slight difference in the susceptibility to random noise in a color receiver with respect to black and white, but the difference is slight. With a good signal-to-noise ratio in the receiver, such random noise interference will be negligible. This is particularly true of modern receivers utilizing the cascode principle in the tuner which provides over 35% noise reduction as compared to older tuners, plus a 2:1 increase in gain.

Adjacent channel interference is more pronounced in color receivers:

True. This is true, however, for only the upper adjacent channel, where the susceptibility amounts to approximately 6 to 8 decibels. Much, however, depends on the trap settings of the receiver (Fig. 2) and how good the selectivity is with respect to proper tuner tracking and video IF alignment. Of course, much also depends on how well the station which is transmitting color adheres to the specifications established for color by FCC. Field strength measurements for any frequency outside of the channel should be held to 60 decibels below the peak picture signal level.

With color tubes, a new aspect ratio is necessary:

False. The 4 by 3 aspect ratio for black and white is also used for color, as is the 2:1 interlace and the 525 lines.

Since color definition appears better than black and white, loss of interlace will not be a serious factor:

False. An interlace is just as important with color reception as it is with black and white. Loss of interlace (Fig. 3) means that there will be line pairing and thus the horizontal line structure will become more coarse. For this reason vertical resolution will suffer and the picture will be degraded to the same proportion that black and white would. Thus, the same precautions with respect to the vertical circuit should be observed in color receivers as with black and white. The vertical hold control should be adjusted for good lock-in, because if the vertical system is set too close to where instability would occur, interlace can be lost even though the picture appears to be stable.

Tuning is much more complicated on a color receiver than it is for black and white:

False. If the viewer adjusts only the front panel controls and does not tinker with rear panel or other hidden controls, tuning procedures are not unduly complex. One additional control is the "chroma" which is used to set the desired intensity of the color hues. Adjustments are somewhat more critical, though the viewer is better able to judge poor picture quality and thus is in a better position to set the front panel controls properly. Improper color reception is, of course, more annoying than slight imperfections in linearity or focus in a black and white receiver.

Servicing adjustments are more complex in color receivers:

True. There are more real panel or concealed controls in the color receiver which must be adjusted by the servicing technicians. The individual control levels for red, green, and blue gain, plus linearity and other controls, make the



Fig. 3 — Interlace pattern appearing on black and white screen. Loss of interlace on color screen will result in a coarse horizontal line structure and degradation of pix.

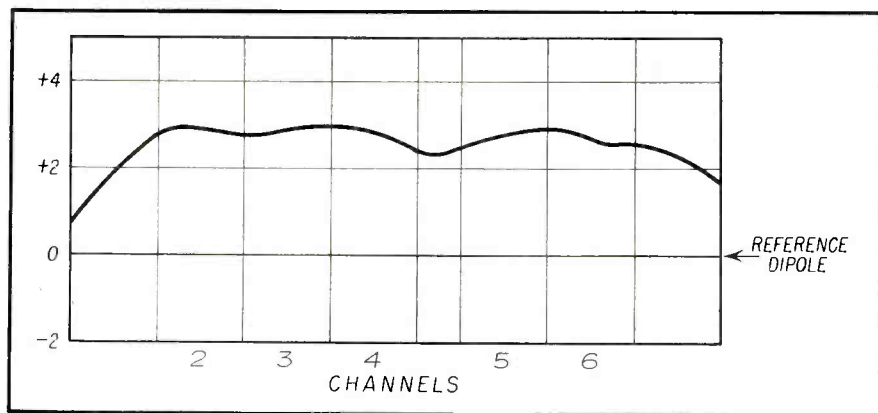

Fig. 4 — Response curve shown above indicates fairly constant response over the entire bandwidth of a single channel. The antenna response must correspond to the above curve in color.

receiver more susceptible to misadjustment and requires a more painstaking procedure for proper operation. It is even more important to stress a "hands-off" policy to the owner with respect to the rear or concealed controls.

Trouble localization is more difficult:

False. It is true that more circuits are present to service and that more work will be entailed, but actual localization of the particular stage or stages which are defective will not take much longer than that for black and white. Clues for localization can still be obtained from symptoms which appear on the screen. Loss of a particular primary color, for instance, would indicate trouble in the specific circuits which handle only such color signals. Interpretation of the specific color which is defective, however, will be difficult on occasion because the various colors are the result of combinations of the primary colors, red, blue, and green. Thus, the interpretation of the defect hinges on the over-all effect present on the screen, or the observation of objects whose color is known. Just as good linearity must be observed with either a station pattern or by use of a crossbar generator; so will a color test pattern be useful for ascertaining the degree of intensity of the primary colors. The chroma control will only vary the over-all effect of the color hues and if the individual controls for red, blue, and green are ineffective in giving true color rendition, circuit components will have to be checked to find which are defective or off-value. For this reason a knowledge of circuit theory will be helpful. Where trouble localization will be particularly difficult for a technician are in those instances where the latter is color blind or partially color blind. In this case he will have considerable difficulty in evaluating the scene which appears on the screen in terms of which colors are deficient and thus which stages are affected.

In some instances a new antenna will have to be installed for proper color reception:

True. For proper color reception it is important that the antenna gain be substantially uniform (over the entire channel as shown in Fig. 4). Since the flat portion of the carrier response curve extends to 4.2 megacycles it is essential that no color signal sidebands be attenuated, or color reception will be impaired considerably.

Many existing antennas of the broadband type do not have a proper length, for instance, for Channel 2 and on occasion for Channel 3. While this impairs nothing but the signal strength to a slight degree for black and white reception, it can have serious effects on color reception for the lower channels. The same factors are also important with respect to Yagi antennas. Many multi-element Yagi antennas have such a high degree of selectivity that sideband components are clipped to a considerable degree. Even for black and white receivers this often diminishes the sound signal, but since the latter is usually received to a better degree than the picture signal, the slight reduction in sound signal level is not too noticeable. Such antennas, however, may attenuate the color components sufficiently to prevent proper color reception.

Color receivers are more susceptible to intercarrier buzz:

False. If the tuner tracking and both the picture and sound stages are aligned properly, the buzz will be minimized at the setting of the fine tuning control which gives the best picture. With intercarrier receivers, of course, this also produces the best sound. The fine tuning control setting is somewhat more critical with a color receiver than with a black and white, since off-tuning effects are more noticeable. Color loss will result from mistuning, and for maximum hue levels the fine tuning must be set carefully.

The Work Bench

by PAUL GOLDBERG

FOUR high voltage troubles have been chosen for this installment. Most high voltage troubles are rather easy to locate. However, this article deals with a few odd ones. What is more important is the methods used in hunting these troubles down.

ADMIRAL 21B1—No Brightness

The receiver was turned on but no brightness appeared. The high voltage cap was removed from the C. R. T. and an attempt to draw an arc to chassis failed. Obviously, there was no high voltage. Next, a screw driver tip was placed close to the 1B3 plate cap but no arc could be drawn. Removing the high voltage transformer plate cap from the 1B3, an arc was again attempted with the screw driver, this time from the transformer plate cap, but without success. This was done to check the 1B3. (There was the possibility that the 1B3 had a short between plate and filament.) The 1B3, 6BQ6, 6W4, and the 6SN7, were replaced individually but without effect. At this point, we knew that the 1B3 was not receiving any horizontal high voltage pulses. The high voltage fuse M401, which was on top of the chassis was found to be OK.

Next, the drive to the 6BQ6 was measured at the grid (Pin #5.) The diagram called for 30 volts negative. The voltage measured here was around zero. Now we knew that the horizontal oscillator energy was not being transferred to the grid of the horizontal output tube (6BQ6.) The 6BQ6 plates were getting red; caused by no negative horizontal oscillator drive. This drive causes the 6BQ6 to operate at a high negative bias. The control grid (Pin #4) of the horizontal oscillator (6SN7) was then checked for the negative grid leak voltage. The voltage measured was about 6 volts negative. This indicated that the horizontal oscillator was operating. (The diagram calls for 7 volts negative.) It should be mentioned here, that the 6W4 boost voltage is utilized for plate voltage for the 6SN7, (horizontal oscillator). However, even though boost voltage is not being supplied because of no horizontal oscillator drive to the 6BQ6, the cathode of the 6W4 will have about the same dc voltage as the plate. This is the voltage that is supplied to the horizontal oscillator.

Knowing these facts, we could assume that the trouble was most likely in the input circuit of the 6BQ6. C421, if open, could cause this trouble. Replacing it, however, did not solve the problem. A check was then made of the saw-tooth shaping circuit which consisted of C420 and R438. This circuit changes the blocking oscillator wave shape (Fig. 1A) to a saw-tooth wave shape. (Fig. 1B). R438, 8.2K was at this point measured, and found to be

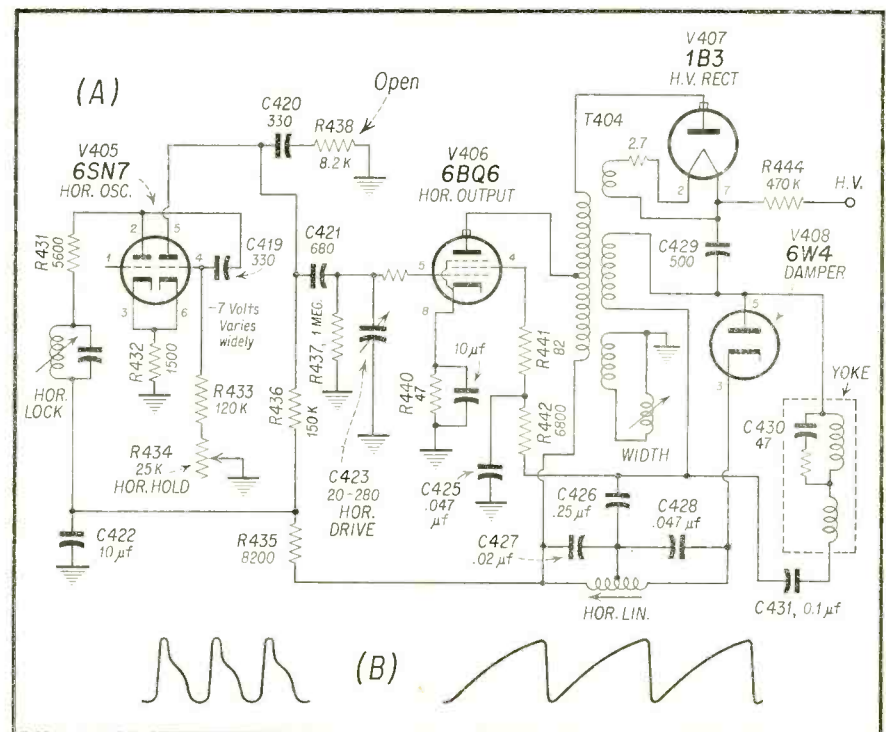

Fig. 1 — Partial schematic, high voltage section Admiral 21B1.

open. Replacing it cured the trouble.

CAPEHART—CX33—Intermittent Blooming

The receiver was turned on and it functioned properly for about five minutes. The raster then started to bloom in and out and at the same time the width would shrink. Before proceeding a proper diagnosis was attempted. Trouble in the filament circuit of the 1B3 was first eliminated as this would not affect the raster's width. Components that would affect frequency in the oscillator (6SN7) were also eliminated, as there was no horizontal frequency trouble involved. At the moment, this was all that could be eliminated in the high voltage section. See Fig. 2.

The 6SN7, 6BQ6, 6W4, and the 1B3 were then replaced individually but without effect. With this type of intermittent trouble, a check was made for burned or obviously defective components. No components of this nature could be found. The 6BQ6, screen resistors (R304, R293, and the cathode resistors, R291, R292), were next checked but measured correctly. (Intermittent troubles can sometimes be caused by resistors which read abnormally when cold and open under operation.)

The receiver was then turned on again. When the trouble occurred, an intermittent breakdown check was made. By placing a long thin screwdriver on individual components and

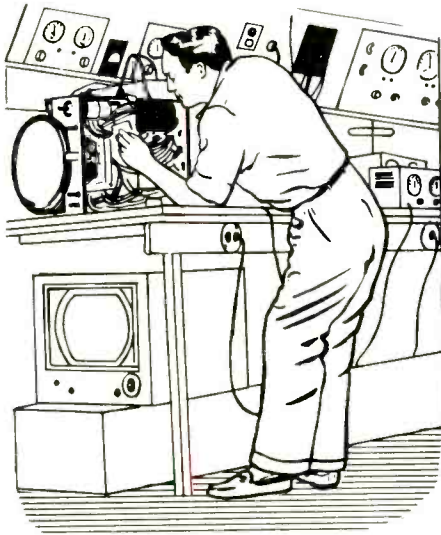

This Month:

HIGH VOLTAGE PROBLEMS

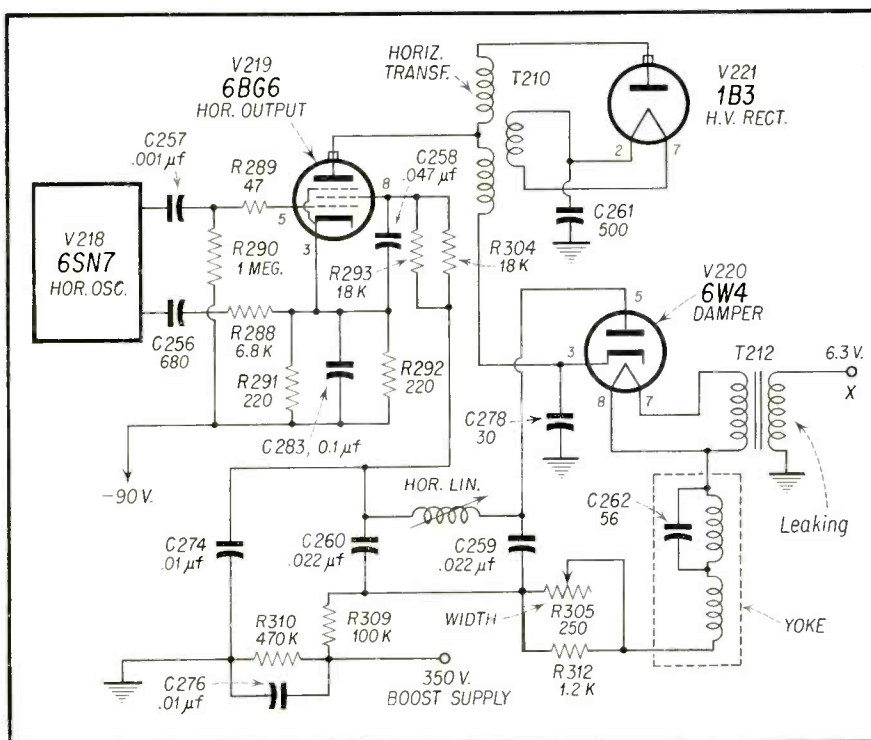

Fig. 2 — Partial schematic, high voltage section Capehart CX33.

the handle in your ear, it is possible to listen for the breakdown. The high voltage transformer, the horizontal linearity coil and condensers C259, and C260, all checked okay by this method. A check was next made of T212, the 6W4 filament transformer. Much to our delight, a loud tick could be heard each time the trouble occurred.

As can be seen from the diagram, this is a filament isolation transformer whose primary is grounded. The receiver was next turned off and the filament leads were clipped from Pin #7 and #8 of the 6W4. A resistance check was made from the filament leads of C212 to ground. The meter read about 7.5 megohms, T212 was replaced and the receiver now operated properly.

Many an intermittent trouble can be found by the simple use of our eyes and ears. Moreover, when troubles are made audible as mentioned above, a speedier repair can be made.

PHILCO 1954 "B", TV181-1B3's Burn Out

When the receiver was brought into the shop the customer had told the serviceman that he had bought the set three months ago and that the 1B3 had been replaced three times within that time. Now, the 1B3 was dead again. See Fig. 3.

Before replacing the tube for the fourth time, the diagram was referred to, to see if there was a method by

which the drive to the 1B3 could be controlled. It was observed that the width control, controlled the voltage to the 6BQ6 screen grid. Thus, it would affect the plate and filament voltage at the 1B3. The width control was then set so it would provide the minimum screen voltage. The 1B3 was then replaced.

After turning the set on and observing that the receiver functioned properly with this minimum width setting, the width control was then turned slowly to maximum. Soon, intermittent blooming of the raster was observed, then a click, and then no raster. It could be properly assumed that another 1B3 was dead.

The 1B3 was replaced again. R103, 4.7 ohms, the 1B3 filament voltage dropping resistor, was next checked and found okay. A decision was made at this point to replace R103 with a 5.6 ohm resistor instead of the 4.7 ohm resistor. This, it was thought would lower the filament voltage enough to avoid any future blown-out 1B3's. The receiver was turned on and with the width control set at maximum screen voltage, or maximum width, the receiver functioned properly for three days. The width control was then properly set and the receiver was sent back to the customer.

WESTINGHOUSE, CH. V-2150-01—No Raster

The receiver was turned on but no raster appeared. No arc could be drawn from the high voltage cap to chassis and no arc could be drawn from the 1B3 cap to the screw driver tip. The 6V6 and 1B3 were replaced individually but without effect. (This high voltage system is not used in many of today's receivers). The high voltage power supply utilizes a 6V6 tube operating as a tuned plate, untuned grid oscillator at

[Continued on page 47]

A Special Purpose

TUBE TESTER

by JACOB ANTHES

Chief Design Engineer, American Scientific Development Co.

SINCE the advent of television, many tube testers have been left behind in the service shop while the repairman goes out on his calls. Tube substitution, instead of tube testing, has frequently become the standard servicing procedure. This practice represents a considerable change from the days of radio, when few repairmen ever left their shops without tube testers.

Advantages of Using a Tube Tester

The great amount of time consumed in setting up for, and testing, the twenty or more tubes in the average TV chassis is the main reason why so many servicemen prefer to use substitution methods. While this may be the fastest way to complete a service call, there are

several serious objections that should not be over-looked.

One objection is that the serviceman, and the customer, gets no indication on the condition of the rest of the tubes in the chassis. In addition to passing up many possible tube sales and the resulting loss of profit, the repairman leaves himself wide open to call-backs and ill feeling, when another tube fails a few days later. Experience shows that many callbacks can be avoided by replacing questionable tubes on the first call.

Another serious objection to substitution as a regular procedure is that the customer gets only the serviceman's word that certain tubes need replacing. A meter indication on a simple "good-bad" scale is still the best possible cus-

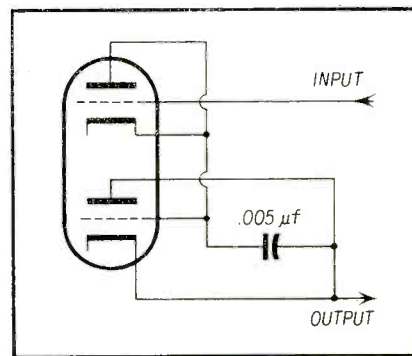

Fig. 3 — Dual tubes, such as the 6S7, 6AL5, etc., are tested in a single operation. This is done by connecting them up in series.

tomor convincer. Few people will object to having needed tubes replaced if they can see the necessity for it themselves on a tube tester meter.

The ASD model TV-20 tube tester was developed primarily for the TV repairman, so that tube testing, instead of substitution, might again become the preferred method as it was in the days of radio. By eliminating all but a very minimum of switching and set up, and by printing tube type and adjustment information directly on the top panel so that no roll chart was necessary, it was possible to design a tester that could check all the tubes in the average TV chassis in a matter of minutes.

Simplicity of Set-up

Most of the switching necessary on general purpose testers was eliminated by using twenty pre-connected sockets. Tube types were then grounded, so that all tubes that had the same or similar pin connections could be tested in a single socket. In several cases it was possible to assign two or more groups to the same socket by using special interconnections. Wherever possible, the tube grouping was arranged so that all horizontal output types would test in one socket, rectifiers in another, if am-

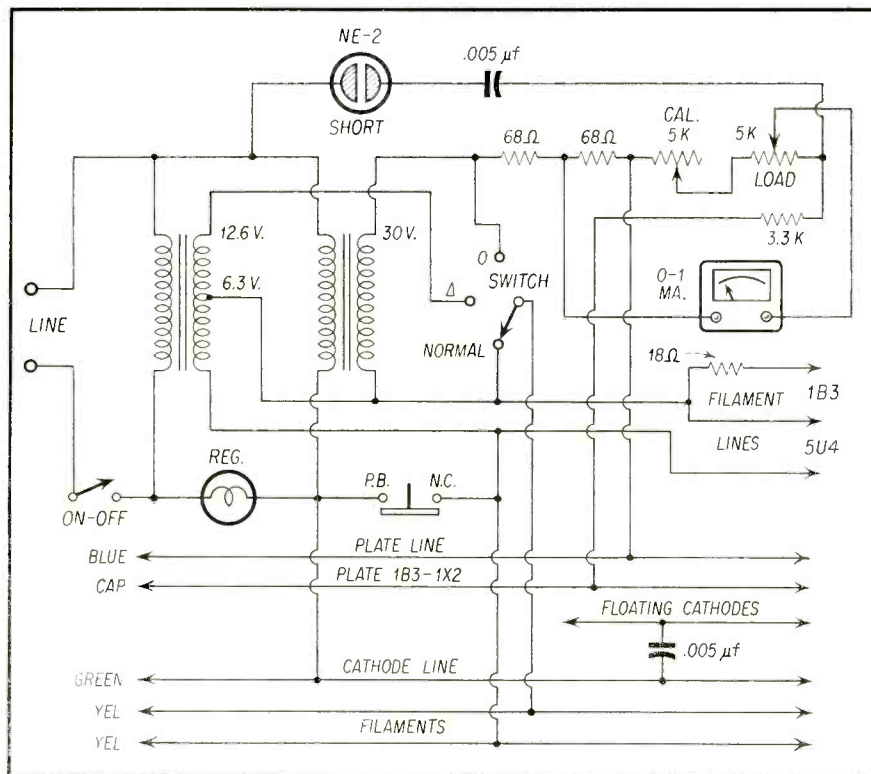
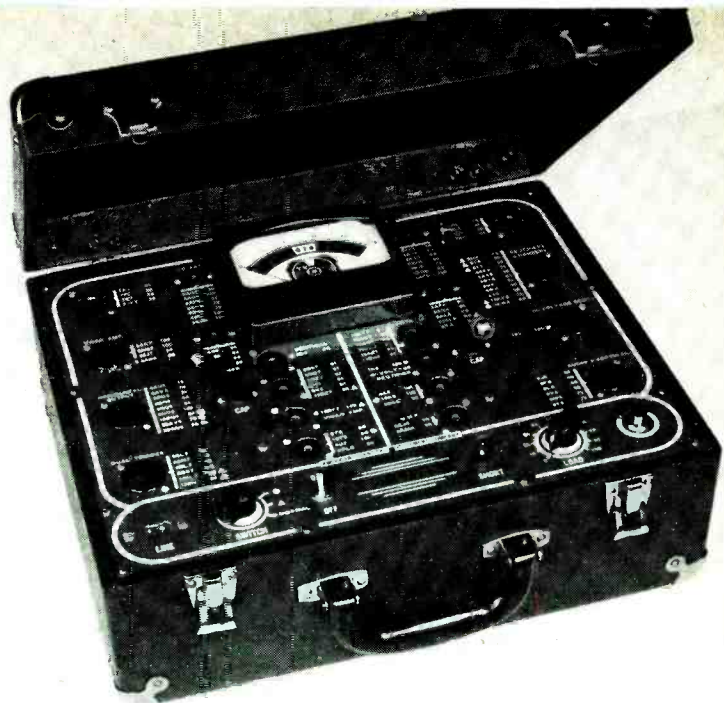

Fig. 2 — Complete circuit diagram of ASD Model TV 20A tube tester.

Fig. 1 — Top view of ASD Model TV 20A special TV tube tester.



**DESIGNED
PRIMARILY
FOR TV TUBES**

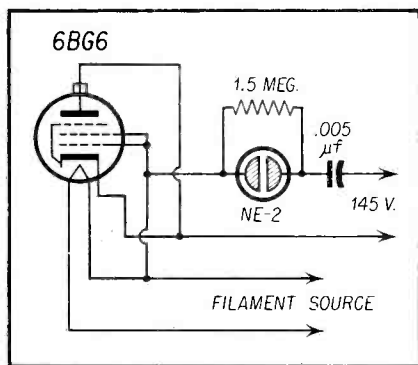

Fig. 4 — Inter-element shorts, leakage, etc., are tested in a single operation as shown by the simplified schematic diagram.

plifiers in a third, and so on. This arrangement makes locating the right socket easy.

The socket connections represented in the 20 combinations on the panel (Fig. 1) had to insure a minimum possibility of not being able to test new tube types in at least one of them. Almost all conceivable connection combinations now in use, and likely to be introduced were wired in. Barring the possibility of a complete deviation from present connection standards, adapting a new tube type should be simply a matter of determining the socket to use and arriving at the proper set-up conditions for it.

The TV-20a tube tester uses a test circuit (Fig. 2) in which the tube under test is connected as an *ac* power rectifier. The meter then measures the rectified output from the tube. All tubes are tested under heavier than normal load conditions. This insures that tubes used in many hard worked TV circuits will be checked under similar load conditions.

Dual tubes, such as the 6SN7, 6AL5, 12AU7, and others are tested in one socket in a single operation. This is done by connecting them in series, as shown in Fig. 3.

The .005 μf capacitor across the lower triode is necessary so that a heater-cathode leakage across the upper half will show up in the short test. It has no effect on the over-all reading of the tube. If one-half of the tube is weak, the meter will so indicate even if the other half is in practically new condition. In effect this series test is like testing the weakest link in a chain.

Inter-element shorts, leakages, and gas are all tested in a single operation, simply by pressing a push button switch. Fig. 4 shows how this is done on horizontal output types.

The heater and the two grids are connected in parallel to one side of a 145 volt source, in series with a neon indicator. The plate and cathode are connected to the other side of the source voltage. A short or leakage between heater and cathode completes the *ac* circuit and the neon indicator will glow. A short from grid to cathode, or from screen or grid to plate also completes the circuit, and the indicator will show it up. A gassy tube will act as a partial conductor, and shows up the same as a leakage current.

The sensitivity of the short and leakage test was intentionally made very high. The neon indicator will glow when the leakage resistance is less than 1.5 meg-ohms. While this will occasionally require some judgment in replacing borderline tubes, such sensitivity is a great asset in locating troublesome tubes in critical circuits, such as sync clippers and amplifiers, cathode followers, *dc* restorers and *agc* amplifiers.

Another control eliminated from the ASD tester is the line voltage adjuster. This was made possible by using a 25 watt series regulator in the primary circuit of the test voltage transformer. The non-linear resistance characteristics of this regulator gives ample compensa-

tion to permit the elimination of this control. The exact extent of this type of compensation is about 75%. The remaining 25% remains uncompensated, and this is desirable. It must be remembered that a TV set that is working in a home in which the line voltage is consistently low, must have "hotter" tubes in it in order to perform properly. If the tube tester is fully corrected for this low line voltage, the tubes in this chassis will not be replaced at the proper level for best operation in the location it is used in.

Every design feature of the ASD tester was conceived with testing speed as the primary goal. Having eliminated most of the set-up, and the roll chart, it was now necessary to remove from the tube line-up all obsolete, radio, and seldom used tube types. This left approximately 100 types, plus picture tubes, representing all of the "most used" types in present day TV sets. While the serviceman may occasionally run into a type not printed on the panel the use of substitution in such isolated cases should not seriously inconvenience him, since so much time has already been saved by testing the popular types that are included on the panel.

The ASD tube tester is a "special purpose" type of tube tester. It is not intended to obsolete or replace the conventional tube tester. There will still be a need for the regular tube tester in the shop or on the counter for all of the non-TV tube types that the TV-20A does not test.

The main applications of the ASD tester are in its use by the TV serviceman on his daily service calls, on the counter as a tester for the "walk in" customer with the paper bagfull of TV tubes, and on the bench so that production line techniques can be used in TV repairing.

A NEW LICENSE BILL

UP FOR CONSIDERATION IN NEW YORK STATE

By **ABRAHAM FRANKEL**

General Counsel of Long Island
Electronic Technicians Association
Inc. (L.I.E.T.A.)

TELEVISION technicians of other states as well as the State of New York should be greatly interested in the progress of the LaFauci Act which is presently in committee of the State Legislature. Since the bill is typical of others under consideration elsewhere and in substance reflects the general form which all licensing bills will take, it becomes a matter of vital interest to the entire electronics industry.

The act contains three distinct subdivisions. In the first, the powers to be granted to the Secretary of State are set forth. In the second, the matter of revocation and suspension of licenses are provided. The third deals with penalties for violation of the act.

Since the enactment proposed sets up crimes that do not heretofore exist and provides for penalties and forfeitures, it is penal in nature. Such penalties and forfeitures being directed exclusively against the television serviceman, it may be said to be selective.

On the date of the enactment of the bill or some short time thereafter, "no person shall engage in the business of servicing or repairing television sets or service or repair television sets for a fee or compensation unless he has first obtained a license therefor from the Secretary of State." It is to be noted that only the repairs of television sets are subject to this provision. All other electronic equipment is exempt therefrom. There is provision for the filing of an application and the payment of a "fee of twenty-five dollars for one year's license." It is therefore apparent that renewal applications with further fees of \$25.00 for each year will be provided.

The Secretary of State "shall have power: 1. To prescribe and examine into the qualifications of applicants." It is to be expected that this power will not personally be exercised by the Secretary of State but by some division of the Department of State either presently existing or especially set up for that purpose. It is to be noted that the qualifications of the applicant is a matter

which the Secretary of State (or his department) will have full discretion. It is probable that the qualifications of applicants will be determined by tests. If the present testing system of said department is used, the test will probably have a written part and a practical part where bench work will be included. It is a matter of pure conjecture whether these tests will be so constructed as to weed out all but highly qualified technicians or whether same will be simple enough to be successfully passed by all technicians who earn their livelihood from television repairs. The latter alternative is more likely.

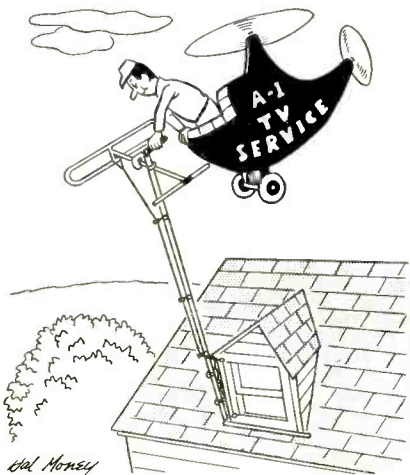

The Secretary of State has power under the proposed law "To license without examination any person applying * * * who shall furnish evidence * * * that he was engaged in the business of servicing or repairing television sets on January first, nineteen hundred fifty-three, and was so engaged for a period or periods of time aggregating one full year within the period of five years immediately preceding the effective date of this section." The effective date will be reached only after enactment. Thus technicians with one year's experience may be licensed without examination. Although the wording of this is permissive rather than mandatory, it is quite probable no examinations will be given to servicemen with one year experience as set forth in the section.

The bill gives to the Secretary of State the further power: "3. To make such rules and regulations respecting

minimum standards of service, number of employees in proportion of number of sets to be served, rates to be charged, and such other matters as he may deem necessary for the proper conduct of such business." It may be expected that the regulations regarding rates to be charged will not concern themselves with minimum rates but will certainly provide for maximum rates as such appears to be the legislative intent. Such rules and regulations that the Secretary of State may choose to promulgate in accordance with his power will have the force of law just as if they were incorporated in the original enactment. It is to be noted that such rules and regulations may pertain to "such other matters as he may deem necessary * * *" This might prove to be a carte blanche.

The Secretary of State has power under the proposed bill: "4. To prepare a standard form or forms of contract to be used by all licensees." and: "5. To require a bond to be furnished in connection with any such contract or contracts, in such amount and subject to such terms and conditions as he may prescribe." This would give the Secretary of State the power to prepare a form not only for time service contracts but also for the ordinary repair job. The bond mentioned would probably take the form of a surety company bond guaranteeing payment of any loss occasioned by the serviceman because of some wrongful or neglectful act in connection with his repair work. It is no guarantee that the customer will recover merely by making a claim but will probably provide for payment by the surety only upon the recovery of a judgment in a court of law by the customer against the serviceman. Since the total damage that possibly may be done to a customer would not exceed the value of the set, it is difficult to imagine why such a bond is needed, every technician being financially responsible enough to respond in damages for such small amount. The bonding company will, of course, require a periodic premium for its bond.

The bill further provides that the Secretary of State "In his own discretion or upon a verified complaint of any person aggrieved, and after giving the licensee an opportunity to be heard

[Continued on page 43]

KEY VOLTAGES

- B+, plate of damper, V702 pin 5 280 vdc
- Boosted B+, cath. of damper, V702 pin 3 460 vdc
- Plates of Vert. OSC., V601 pin 2 95 vdc
pin 5 200 vdc
- Plate of Vert. Out., V602 pin 9 420 vdc
- Plate(s) of Hor. OSC., V702 pin 2 200 vdc
pin 5 115 vdc
- Grid of Hor. Out., V703 pin 5 —17 vdc

All voltages are measured with a VTVM connected between the tube pins and chassis.

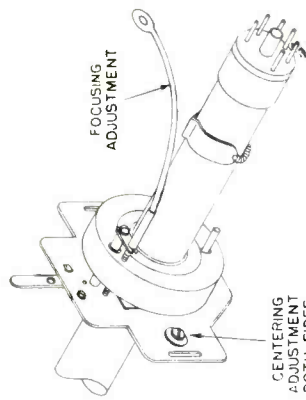

CENTERING ADJUSTMENT BOTH SIDES

Focus and Centering Adjustment

HOFFMAN

- Chassis 400—21 Models 21M721, 21B723, 21M722, 21P724.
- Chassis 401—21 Models 21M146, 21B147, 21P148, 21M320, 21B321, 21P322.

TUBE LIST

SYMBOL TYPE CIRCUIT FUNCTION

V1	6BZ7 or 6BQ7	R-F Amplifier
V2	6J6	OSC-Mixer
V101	6AU6	1st Sound IF.
V102	6AU6	2nd Sound IF.
V103	6AL5	Ratio Detector
V104	6AV6	Audio Amp.
V105	6K6GT	Audio Output
V201	6CB6	1st Picture IF.
V202	6CB6	2nd Picture IF.
V203	6CB6	3rd Picture IF.
V204	6CB6	4th Picture IF.
V205	1/2 6AL5	Video Detector
V205	1/2 6AL5	Delayed AGC
		Clamp
V301	6AH6	Video Amp.
V302	21ZP4A	Picture Tube
V302	24CP4A	Picture Tube
V401	6AU6	AGC Keyer
V501A	1/2 12AT7	1st Sync Sep.
V501B	1/2 12AT7	2nd Sync Sep.
		Phase Splitter
V601	6SN7GT	Vertical OSC
V602	6S4	Vertical Output
V602	6W6	Vertical Output
V701	6AL5	Horiz. Phase Detector
V702	6SN7	Horiz. Oscillator
V703	6CD6	Horiz. Oscillator
V704	6W4	Damper
V705	1B3	H.V. Rectifier
V801	5U4	L.V. Rectifier
V802	5U4	L.V. Rectifier

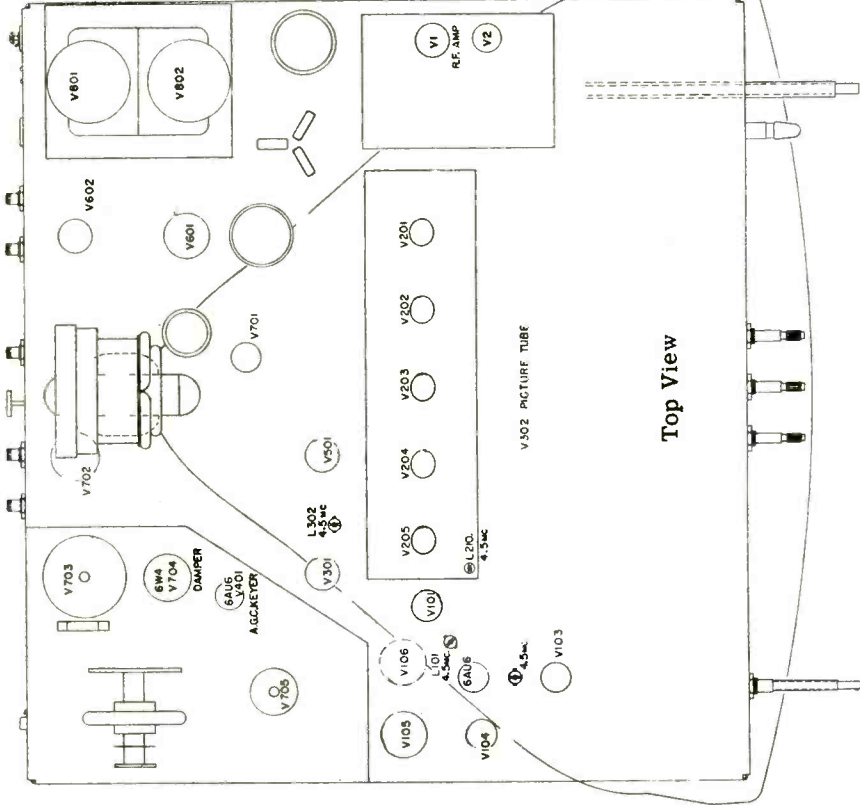

Top View

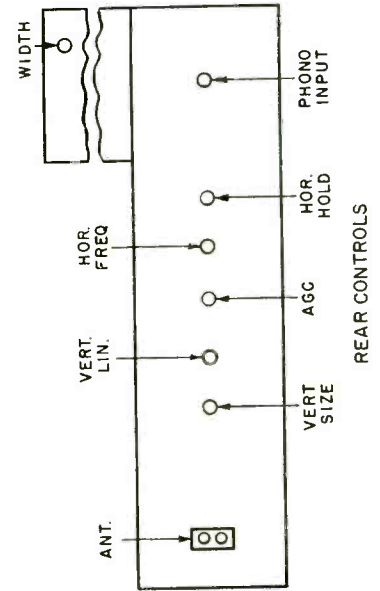

REAR CONTROLS

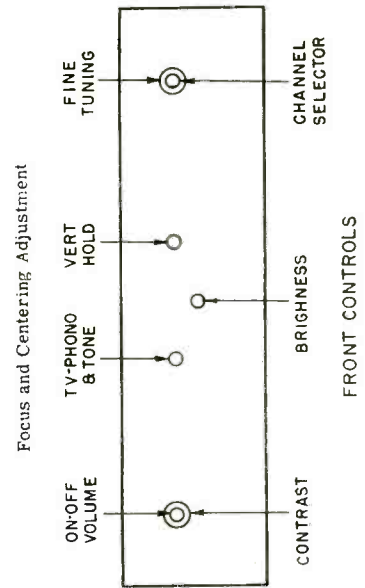

FRONT CONTROLS

ADJUSTMENTS

HORIZONTAL DRIVE ADJUSTMENT

1. Turn the HORIZ. DRIVE control counterclockwise until a drive bar (thin, light vertical line) appears.
2. Turn the control clockwise until the drive bar just disappears. If no drive bar is obtained, set the control at the maximum counterclockwise position.

HORIZONTAL HOLD CONTROL

The HORIZONTAL HOLD control provides a vernier adjustment for the horizontal multi-vibrator operating frequency. Proper setting depends on correct adjustment of the HORIZ. FREQ. and HORIZ. DRIVE controls.

Turn the Horizontal Hold control until bending of the top portion of the picture is eliminated. This is best determined by noting the vertical lines in the picture.

HORIZONTAL FREQUENCY CONTROL

1. Turn the Horizontal Hold control to mid-range.
2. Turn the HORIZ. FREQ. control counterclockwise while switching the CHANNEL SELECTOR on and off channel until sync is lost.
3. Turn the control clockwise and check the number of bars which appear just before pull-in of the picture. Check circuit for abnormal operation if less than two bar pull-in occurs.
4. Continue turning control clockwise while switching the CHANNEL SELECTOR on and off channel until sync is lost.
5. Turn the control counterclockwise and check the point where picture pull-in occurs.
6. Turn the control an additional $\frac{1}{2}$ turn counterclockwise.

ION TRAP

The effects of the FOCUS ADJ. ion trap, and centering control orientation are slightly interdependent and one or two sequential adjustments of each may be necessary for optimum setting of these controls. Always set the ion trap for maximum raster brightness.

CAUTION:

Never attempt to center the picture by misadjustment of the ion trap.

Set the BRIGHTNESS and CONTRAST controls about midrange, never at maximum setting, to avoid damaging the picture tube. Move the ion trap over the "flags" of the picture tube first anode. Rotate the ion trap on the picture tube neck until light appears on the screen. After initial light has been obtained, move the ion trap back and forth and further rotate it to obtain the brightest raster. If the receiver is equipped with a Raundal picture tube, the optimum ion trap setting is indicated by minimum green glow in idle the tube neck.

RASTER CENTERING

It is best to adjust the picture linearity and size, using a test pattern, before centering the picture. If picture tilt exists, temporarily loosen the wing screw at the top of the deflection yoke and rotate the yoke until the tilt is eliminated. Make certain that the deflection yoke is seated as far forward on the picture tube neck as it is possible to move the yoke.

Raster centering is accomplished by adjusting the center control. By moving the centering control up and down, the raster moves from left to right. By moving the control from left to right, the raster moves up and down.

AUTOMATIC GAIN CONTROL

This control and its associated circuits regulate R-F and I-F AGC voltages (within the limits of the AGC system). When the AGC control is turned full clockwise the greatest bias appears on the I-F AGC bus and the lowest bias appears on the R-F AGC bus for a given signal. When the control is reversed the I-F AGC bias voltage is minimum and the R-F AGC bias is maximum for a given signal. This source of high R-F bias is very useful when strong signals cause the video stages to overload, clipping the sync pulses. In very strong signal areas turn the AGC control counterclockwise until loss of sync is eliminated. Do not turn more than necessary because increase in bias on the R-F amplifier with simultaneous decrease in I-F bias will lead to excessive noise in the picture after a certain point. Conversely, in weaker signal areas the control should be turned clockwise so that the R-F bias is reduced and the I-F bias is increased. This condition will improve the signal to noise ratio, minimizing "snow" in the picture. Again, do not over control or I-F stages may be overdriven. The optimum point is a function of signal strength. Use picture quality as an indicating device and adjust for optimum performance.

FUSE PROTECTION

The source of fuse protection is in the horizontal output screen circuit and damper circuit. A $\frac{1}{4}$ -ampere fuse is held in a fuse clip located inside of the high voltage cage.

FOCUS ADJUSTMENTS

Magnetic focusing is being employed in the 400 series chassis. For correct focus adjustment, adjust focus control for maximum focus range. Readjust ion trap after making the initial focus adjustment. Check neck of picture tube, making sure it is in center of focus coil. Because magnetic focusing is being used, the off-on control switch now performs the function of removing the bias from the picture tube so that when the set is turned off, the small electron beam that is present will be out of focus, therefore preventing damage to the face of the picture tube.

HOFFMAN TROUBLE SHOOTING CHART

INSUFFICIENT RASTER HEIGHT

Vert. Size and Lin. con.
V601, V602, V801, V802
Check 0.1 μ f caps. connected to pin 5 of V601
Vert. Out. trans.
Low line voltage

NO VERT. DEF.

V601, V602
Check 0.1 μ f cap. connected to pin 5 of V601
Check 0.0039 μ f cap. connected to pin 2 of V601
Vert. Defl. coils (yoke)
V. O. T. and Vert. Osc. trans.

NO VERT. SYNC.—HOR. SYNC. OK

Vert. Hold con.
Vert. Int. network
V101, V501, V601, V602
Check 0.0039 μ f cap. connected to pin 2 of V601

NO HOR. OR VERT. SYNC.—PIX SIGNAL OK

V401, V501
Check cap. connected to pin of V501 through a 470K Ω res.

NO HOR. SYNC.—VERT. SYNC. OK

Hor. Hold and Freq. con.
V701, V702, V703
Check 470 μ f cap. connected to pin 2 of V702

NO SOUND—PIX OK

Tuner fine tuning
Vol. con.
Speaker (open voice coil or defective connection)
Sound and Vid. IF alignment L210, L101
Det. alignment T101
V101, V102, V103, V104, V105, V106

WEAK SOUND—PIX OK

Tuner fine tuning
Vol. con.
V2, V101, V102, V103, V104, V105, V106
Sound and Vid. IF alignment L210, L101
Det. alignment T101

NOISY SOUND—PIX OK

Vol. con.
V101, V102, V103, V104, V105, V106
Check sound system for loose connections
Speaker
Sound IF and Det. alignment L210, L101 and T101

SYNC. BUZZ IN SOUND

Tuner fine tuning
V101, V102, V103, V205, V401
Sound IF and Det. alignment L210, L101 and T101

INTERMITTENT RASTER—SOUND OK

Brightness con.
V702, V703, V704, V705
Hor. Out. trans.

INSUFFICIENT BRIGHTNESS

Ion trap
Brightness and Hor. Drive con.
V302, V703, V704, V705, V801, V802
Low line voltage

INSUFFICIENT RASTER WIDTH

Hor. Drive and Width con.
V703, V704, V801, V802
Check 0.0017 μ f and 470 μ f caps. connected to hor. drive con.
Hor. Out. trans.
Low line voltage

NO RASTER—SOUND OK

Brightness con.
Check HV Fuse F701 (0.25 Amps.)
Ion trap
V302, V702, V703, V704, V705
HV trans. Hor. yoke CRT connections

WEAK PIX—SOUND AND RASTER OK

Tuner fine tuning
Contrast con.
V2, V201, V202, V203, V204, V205, V301, V401

POOR HOR. LIN.

Hor. Lin. and Drive con.
V703, V704
Check 0.01 μ f cap. connected to pin 8 of V703
Hor. Out. trans.

POOR VERT. LIN.

Vert. Size and Lin. con.
V601, V602
Check 0.1 μ f cap. connected to pin 5 of V601

Check 50 μ f Elec. cap. connected to pin 2 of V602
Vert. Out. trans.

PIX JITTER SIDEWAYS

Hor. Hold and Freq. con.
V701, V702, V703
Check 0.0001 μ f cap. connected to pin 7 of V701

PIX JITTER UP & DOWN

Vert. Hold and Contrast con.
V401, V501, V601, V602

SMEARED PIX

Tuner fine tuning
Contrast con.
V201, V202, V203, V204, V205, V301, V401
Check Vid. Det. and Amp. peaking coils
IF and RF alignment

MAJESTIC

SERIES 112-17"
113-21"

TUBE LIST

SYMBOL/TUBE	CIRCUIT FUNCTION
V1	6BC5/6CB6 RF Amp.
V2	6J6 Osc.-Mixer
V3	6CB6 1st Video IF.
V4	6CB6 2nd Video IF.
V5	6AU6 3rd Video IF.
V6	6AL5 AGC and Video Det.
V7	12BH7 Video Amp.
V8	6AU6 Sound IF Amp.
V9	6T8 Ratio Det., AF Amp.
V10	6K6 Audio Output
V11	6SN7 Sync Sep.-Amp.
V12	6C4 Vertical Osc.
V13	6V6 Vertical Output
V14	6SN7 Hor. Osc.-Control
V15	6AV5 Hor. Output
V16	6W4 Hor. Damper
V17	1B3 H. V. Rect.
V18	5U4 L. V. Rect.
V19	Picture Tube

KEY VOLTAGES

- B+, plate of damper, V16 pin 5 245 vdc
- Boosted B+, cath. of damper, V16 pin 3 465 vdc
- Plate of VERT. OSC., V12 pin 5 200 vdc
- Plate of Vert. Out., V13 pin 3 240 vdc
- Plates of Hor. Osc. (and control) V14 pin 5 183 vdc
- Grid of Hor. Out., V15 pin 1 -27 vdc

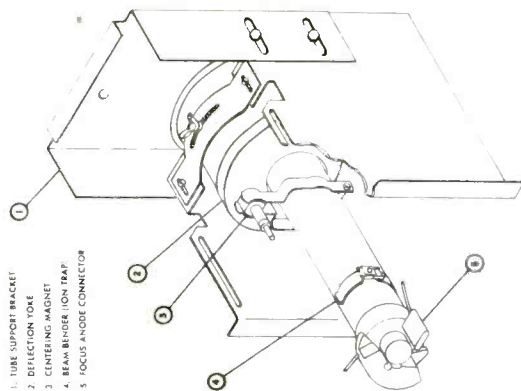

DEFLECTION YOKE AND CENTERING MAGNET ASSEMBLY

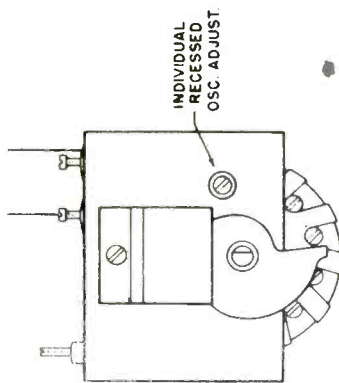

TUNER FRONT VIEW

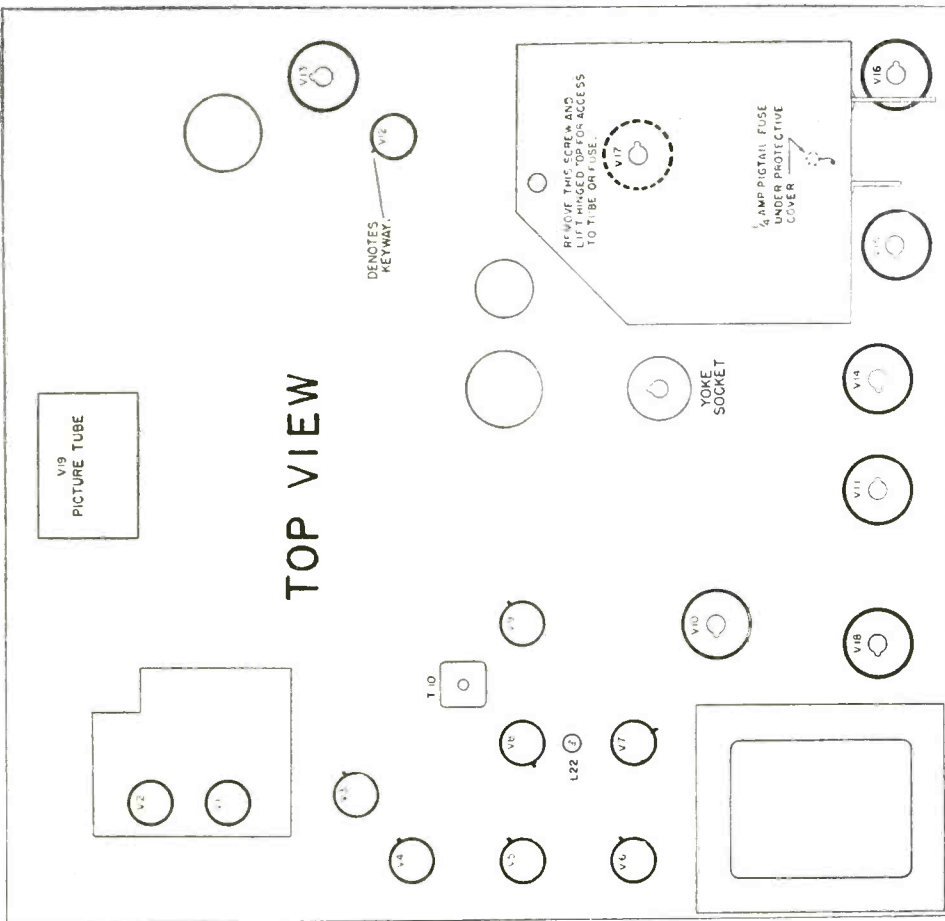
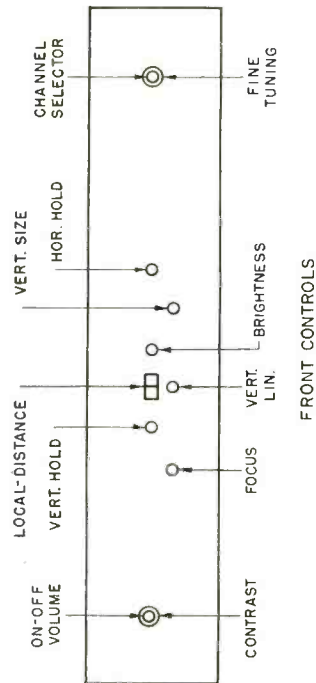

TOP VIEW

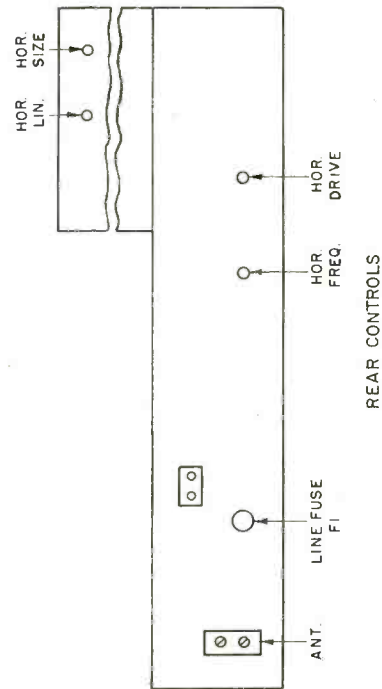

BEAM BENDER (ION TRAP) ADJUSTMENT

1. Position the beam bender on the glass neck approximately $\frac{1}{2}$ " from the picture tube base.
2. Advance the BRIGHTNESS control almost fully clockwise.
3. Starting from this position, adjust the Beam Bender by moving it forward or backward, and at the same time rotating it slightly around the neck of the tube until the brightest raster appears on the screen. If two maximum brightness positions are found, the one nearest the tube base is the correct setting. This adjustment should be done quickly to avoid damaging the gun structure.
4. Adjust the BRIGHTNESS control to maximum, fully clockwise.
5. Re-adjust the Beam Bender carefully for maximum raster brilliance.
6. The Beam Bender must be adjusted at all times for maximum brightness. A misadjusted Beam Bender can damage the picture tube in a matter of seconds and it is of utmost importance to make this the first adjustment when the set is turned on and the last adjustment before the cabinet back is reinstalled.

IMPORTANT—The adjustment of the Beam Bender (Ion Trap magnet) must be performed immediately after the receiver warms up. If any length of time is permitted to elapse while the receiver is on, and while the Beam Bender is misadjusted, serious damage to the internal structure of the cathode-ray gun may result.

HORIZONTAL A.F.C. ADJUSTMENT

In order to check this adjustment tune in a station, preferably one that is transmitting a test pattern. If difficulty is encountered in locking the picture horizontally or if it locks-in only when the Horizontal Hold Control is at either end of its rotation, adjust the Horizontal A.F.C. Control as follows:

1. Turn CONTRAST down about half way.
2. Turn HORIZONTAL HOLD CONTROL fully counterclockwise.
3. If the picture is not locked in, turn the HORIZONTAL A.F.C. control till it does lock-in.
4. Momentarily interrupt the signal by switching the channel selector off channel and then back. The picture should just fall out of sync. If it does not, turn the Horizontal A.F.C. adjustment screw slightly clockwise and again momentarily interrupt the signal. Continue this procedure until the picture just falls out of sync. only when the signal is interrupted.
5. Rotate the Horizontal Hold Control clockwise until the picture falls into sync. The

picture should now stay in sync. throughout most of the range of the Horizontal Hold Control.

6. If the picture cannot be made to hold sync., carefully repeat the above procedure. If difficulty is still encountered, it may be necessary to make a complete alignment of the horizontal oscillator transformer using an oscilloscope.

PICTURE WIDTH ADJUSTMENT

Adjust the HORIZONTAL SIZE control slot-screw, located at the rear of the High Voltage cage at the rear of the chassis, for correction of horizontal width. The large outer arcs of the test pattern should coincide with the edge of the picture mask.

Adjust the HORIZONTAL DRIVE control trimmer for horizontally symmetrical pattern, and elimination of any existing vertical bars in left center of picture. The final adjustment should have the control at least $\frac{1}{2}$ turn counterclockwise from the maximum clockwise position.

The readjustment of the HORIZONTAL A.F.C. control may now be necessary.

PICTURE CENTERING

Press the yoke firmly against the flare of the tube. An improperly positioned yoke will cause shadows on the corners of the raster. This indicates that the electron beam is striking the neck of the picture tube.

Position the centering magnet assembly approximately $\frac{1}{2}$ " to $\frac{3}{4}$ " behind the yoke. Centering is accomplished by rotating the small horizontal shaft. When the shaft of the magnet is above the tube vertical centering results, if the entire magnet assembly is rotated on the picture tube neck, until the shaft is on either side of the neck, it will center horizontally. When both vertical and horizontal centering is necessary, rotate the magnet assembly while rotating the small magnet shaft. Improper adjustment may cause neck shadow. Check the yoke position. Then readjust the centering magnet for proper centering without neckshadow. Readjust the Beam Bender for maximum brightness.

FOCUSING ADJUSTMENTS

1. Adjust BRIGHTNESS and CONTRAST controls so that the raster brilliance corresponds to that of an average picture.
2. Adjust focus control for best focus. Some electrostatic tubes will focus properly over the entire range of the focus control. This is no defect, it merely indicates an exceptionally well balanced gun structure. Readjust the Beam Bender for maximum brightness.
- 3.

MAJESTIC TROUBLE SHOOTING CHART

INSUFFICIENT RASTER HEIGHT

Vert. Size and Lin. con.
V12, V13, V18
Check 0.047 and 0.1 μ f caps. connected to red lead of vert. osc. trans.
Vert. Out. trans.
Low line voltage

NO VERT. DEFL.

V12, V13
Check 0.047 and 0.1 μ f caps. connected to red lead of vert. osc. trans.
Vert. Defl. coils (yoke)
V. O. T. and Vert. Osc. trans.

NO VERT. SYNC.—HOR. SYNC. OK

Vert. Hold con.
Vert. Int. network
V11, V12, V13
Check 4700 μ f caps. connected to yellow lead of vert. osc. trans.

NO HOR. SYNC.—VERT. SYNC. OK

Hor. Hold, Freq. and Stabilizing con.
V14, V15, V16
Check 330 μ f cap. connected to pin 4 of V14

DISTORTED SOUND

Tuner fine tuning
V2, V8, V9, V10
Check Couplate connected to pin of V10
Sound and Vid. IF alignment L22
Det. alignment T10

NO SOUND—PIX OK

Tuner fine tuning
Vol. con.
Speaker (open voice coil or defective connection)

Sound and Vid. IF alignment L22

Det. alignment T10
V8, V9, V10

NOISY SOUND—PIX OK

Vol. con.
V8, V9, V10
Check sound system for loose connections
Speaker
Sound IF and Det. alignment L22 and T10

SYNC. BUZZ IN SOUND

Tuner fine tuning
Contrast Con.
V6, V8, V9
Sound IF and Det. alignment L22 and T10

ENGRAVED EFFECT IN PIX

Tuner fine tuning
Contrast con.
V2, V3, V4, V5, V6, V7, V19
Check 0.22 μ f caps. connected to pin 2 of V7
Check Vid. Det. and Amp. peaking coils

VERT. BARS

Hor. Drive con.
V15, V16
Check 56 μ f cap. connected to yoke terminals 1 and 2
Defl. yoke ringing

PIX BENDING

Hor. Hold and Freq. con.
Hor. Stab. Adj.
V14, V15
Check 0.022 and 0.25 μ f cap. connected to pin 3 of V14

WEAK OR NO PIX—SOUND WEAK—RASTER OK

Tuner fine tuning
V1, V2, V3, V4, V5, V6
RF and IF alignment

INTERMITTENT RASTER—SOUND OK

Brightness con.
V14, V15, V16, V17, V19
Hor. Out. trans.

INSUFFICIENT BRIGHTNESS

Ion trap
Brightness and Hor. Drive con.
V15, V16, V17, V18, V19
Low line voltage

INSUFFICIENT RASTER WIDTH

Hor. Drive and Size con.
V15, V16

Check 0.047 μ f cap. and 8.2K Ω res. connected to pin 8 of V16
Hor. Out. trans.
Low line voltage

NO RASTER—SOUND OK

Brightness con.
Check HV Fuse F2 (0.25 Amps.)
Ion trap
V14, V15, V16, V17, V19
HV trans. Hor. yoke CRT connections

WEAK PIX—SOUND AND RASTER OK

Tuner fine tuning
Contrast con.
V2, V3, V4, V5, V6, V7

POOR HOR. LIN.

Hor. Lin. and Drive con.
V16, V17
Check 0.047 and 0.035 μ f caps. connected to hor. lin. coil
Hor. Out. trans.

PIX JITTER SIDEWAYS

Hor. Hold and Freq. Con.
V14, V15
Check 0.0022 μ f cap. connected to pin 1 of V11

SELL & SERVICE

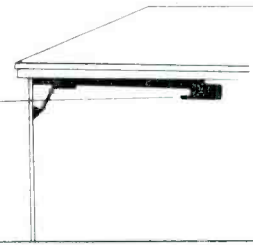

RADIO CONTROLLED GARAGE DOOR OPERATORS

by **SAN D'ARCY**

In another of his series on sales and service "naturals" for the Service Dealer the author describes an item that should be right up his alley.

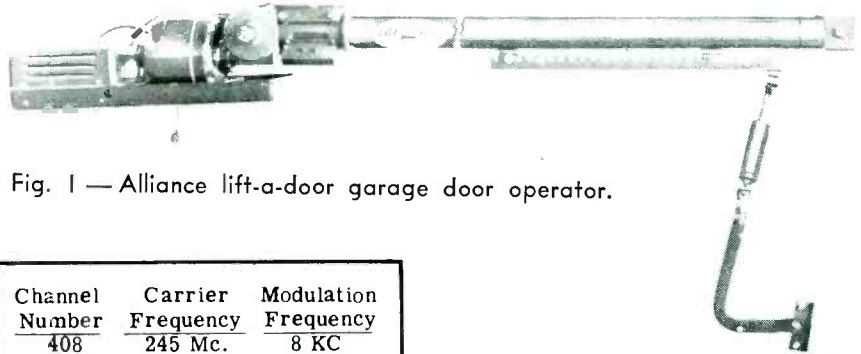

Fig. 1 — Alliance lift-a-door garage door operator.

SINCE radio servicing became a business those engaged in it have had one serious handicap to overcome. I refer to what has become known as the "summer slump"—that eight to ten week period when the cash register seems to be more decorative than useful.

The coming of television to many communities eradicated the slow-down period for a while, but then, after most TV buyers got settled, sure 'nuf, the slump came around again. Service Dealers, of course, don't like this seasonal income decline because their overhead is constant. No boss likes to lay off good helpers in order to keep outlay even with income.

Strangely enough, the ten-week "slump period" referred to affects Service Dealers in all parts of the country although, for climatic or geographic reasons, it does not necessarily occur at the exact same time. But what to do about it has always been a problem.

Of late, several new items have been put on the market and they are the answer to the Service Dealer's prayers. Recently in this journal's editorial columns mention was made that additional income could be obtained during slow periods by selling and installing

Channel Number	Carrier Frequency	Modulation Frequency
408	245 Mc.	8 KC
410	" "	10 KC
412	" "	12 KC
*415	" "	15 KC
508	255 Mc.	8 KC
510	" "	10 KC
512	" "	12 KC
*515	" "	15 KC
608	265 Mc.	8 KC
610	" "	10 KC
612	" "	12 KC
*615	" "	15 KC
708	275 Mc.	8 KC
710	" "	10 KC
712	" "	12 KC
*715	" "	15 KC
808	285 Mc.	8 KC
810	" "	10 KC
812	" "	12 KC
*815	" "	15 KC

Table 1 — Carrier frequencies corresponding to channel numbers. When replacement units or extra transmitters are ordered the channel number must be specified to obtain the correct frequency.

remote tuning control units for TV sets. It was also suggested that air conditioning maintenance work, very elemental and easy to do, would be worthwhile. Other ideas in this vein were: Putting on replacement TV antennas; sales campaigns; stressing battery set and auto radio checkups, etc. Now we have another idea that seems to be "a natural" for Service Dealers and Independent Servicemen alike selling and installing—Radio Controlled Garage Doors.

Practically every private house in the USA has a garage and almost all of them, especially those built since 1930, have doors that slide up and down, open and close, on metal rails, or what the building trade calls a "curved track." Upwards of fifteen million curved track garage doors are used daily, but less than twenty thousand of these are equipped with radio, or, electronic-controlled opening and closing devices. So, at present, there are fifteen million prospective customers—and the figure increases daily as new homes are built—who might buy a radio-controlled garage door operating device. Being radio-controlled, I say they are in the category of "naturals" for Service Dealers and Servicemen.

This is true because now a firm well known to all radiomen has put on sale through electronic parts distributors the "Lift-A-Dor" radio-controlled garage door operating unit. Whereas, in the past, radio-controlled units were high-priced, ranging from \$400.00 upward, and hard to obtain because of poorly controlled distribution outlets, Alliance's new "Lift-A-Dor" is priced to sell for a little more than \$200.00 including

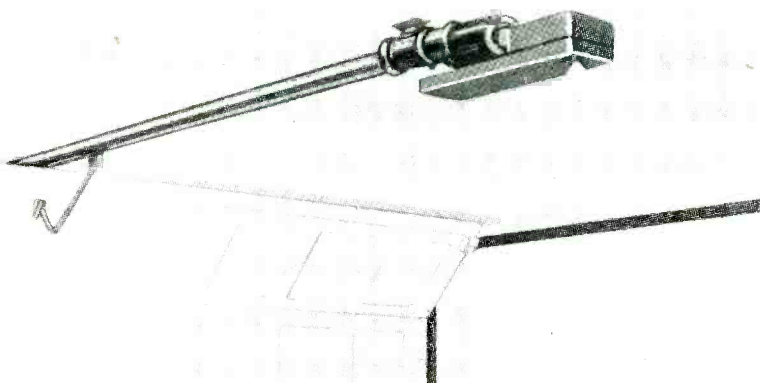
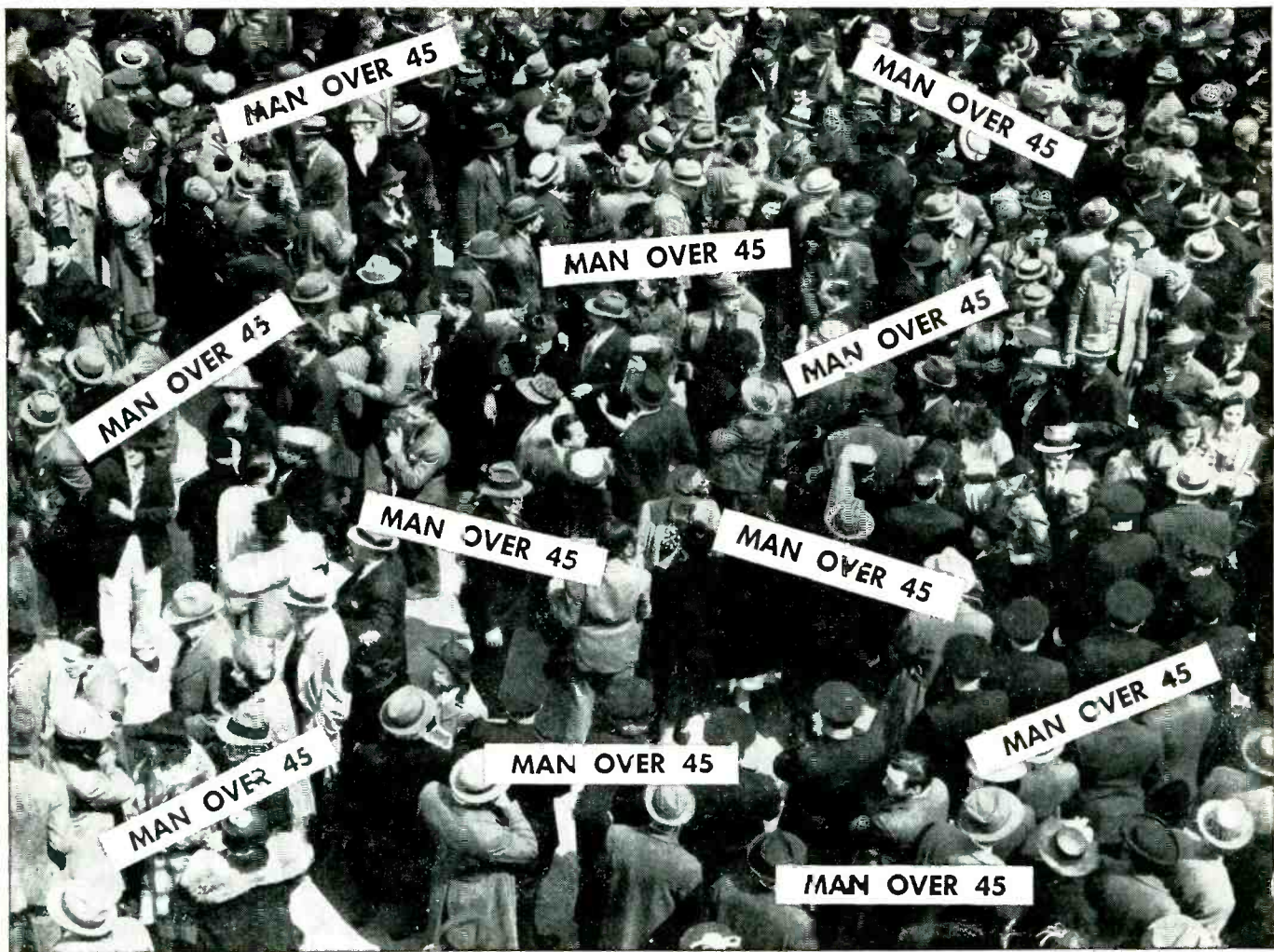

Fig. 2 — Typical installation of unit showing attachment to garage door.



But why MEN over 45?

Our doctors still don't know *why*, but if you are a man over 45 you are six times as likely to develop lung cancer as a man of your age twenty years ago. They *do* know, however, that their chances of saving your life could be about *ten times* greater if they could only detect cancer long before you notice any symptom in yourself. (Only 1 in every 20 lung cancers is being cured today, largely because most cases progress too far before detected.) That's why we urge that you make a habit of hav-

ing your chest X-rayed every six months, no matter how well you may *feel*. The alarming increase of lung cancer in men over 45 more than justifies such precautions. Far too many men die needlessly!

Our new film "The Warning Shadow" will tell you what every man should know about lung cancer. To see this film and to get life-saving facts about other forms of cancer, phone the American Cancer Society office nearest you or simply write to "Cancer"—in care of your local Post Office.

American Cancer Society



cost of installation. The packaged unit lists at \$179.95 and Service Dealers get their standard trade discount so their net cost is about \$146.00. As a normal installation fee would approximate \$50.00. (Installation time is figured at one to two hours), the customer would pay about \$230.00 and the Service Dealer would realize the gross difference, or, \$84.00 per installation.

Installing The Receiver Control

Now, without further ado, let's describe the radio controlled units themselves. Fig. 1 shows the garage door operating unit. This consists of the receiver and relay controlled unit on the extreme left, followed by the motor and the "Lift-A-Door" mechanism. A typical installation is shown in Fig. 2. Naturally, the first installation will take longer than subsequent ones because one has to get his "know-how" the hard way. However, full instructions are made available to permit the installer to get a clear picture of what he has to do.

The Lift-A-Dor receiver control, when shipped from the factory, has been pre-tuned to one of twenty frequency channels. See Table 1. The sensitivity has been set to permit operation, under normal conditions, at a distance of at least 100 feet. No additional adjustment is necessary but it is

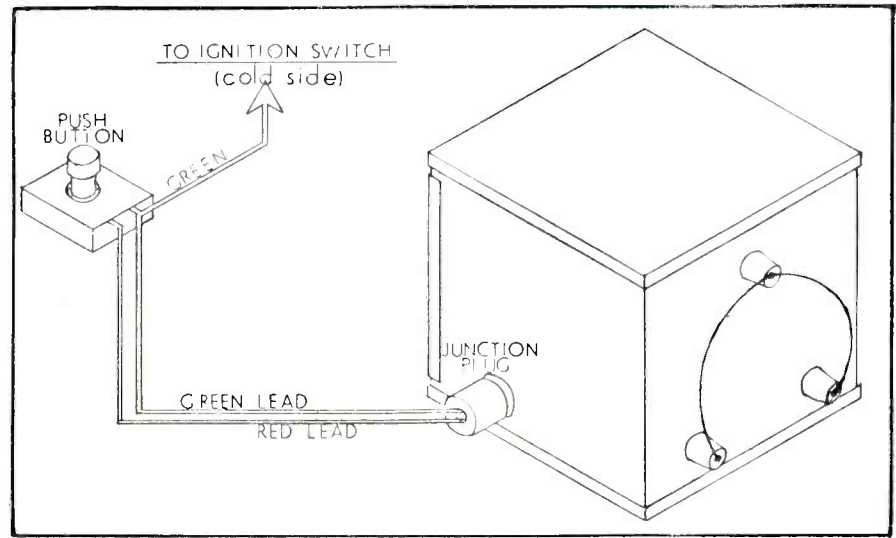

Fig. 4—Connections between transmitter, push button and ignition switches.

advisable to reduce the distance control to no greater than 150 feet if the distance exceeds this figure. If the Lift-A-Dor receiver control is shipped as a control link, the accompanying transmitter had been carefully aligned to it. Should the control not function properly, the complete control link should be returned to the factory.

It might be further added that in operation the approaching car signals

the receiver, which is on continuously, and which sets into operation a thermal switch. The latter, in turn, turns on the motor which drives the door-opening mechanism. An additional switch is provided which is mounted on the wall of the garage. Pushing this switch sets into operation the mechanism which now closes the garage door. If desired, this switch in combination with a key-locking mechanism may be mounted outside the garage. Thus, if the garage has no additional door, the external switch is most appropriate.

Transmitter

The transmitter is shown in Fig. 3, and is easily installed under the hood of the automobile. Fig. 4 illustrates the connections between the transmitter, the push button switch, and the ignition switch. A wiring diagram of the transmitter is shown in Fig. 5. The push button switch is mounted on the dash or on the steering wheel, wherever it is most convenient. Adapters are available to permit operation of the transmitter if the car has a 12 volt system.

Supplemental controls are available so that the owner can open and close the garage door from within his home; and if he has two cars he can have an extra control unit with the same frequency installed in the second car also.

The installer has a wide range of radio frequencies to select from as will be noted by referring to Table 1. This provision allows for the sale, installation, and use of many radio-controlled garage door units within a small residential area without their conflicting with each other. No F.C.C. license is required.

Here then, is a natural accessory for the enterprising service dealer. Its price is within the range of people in the middle income bracket, and as such, becomes an item that should have mass sales appeal.

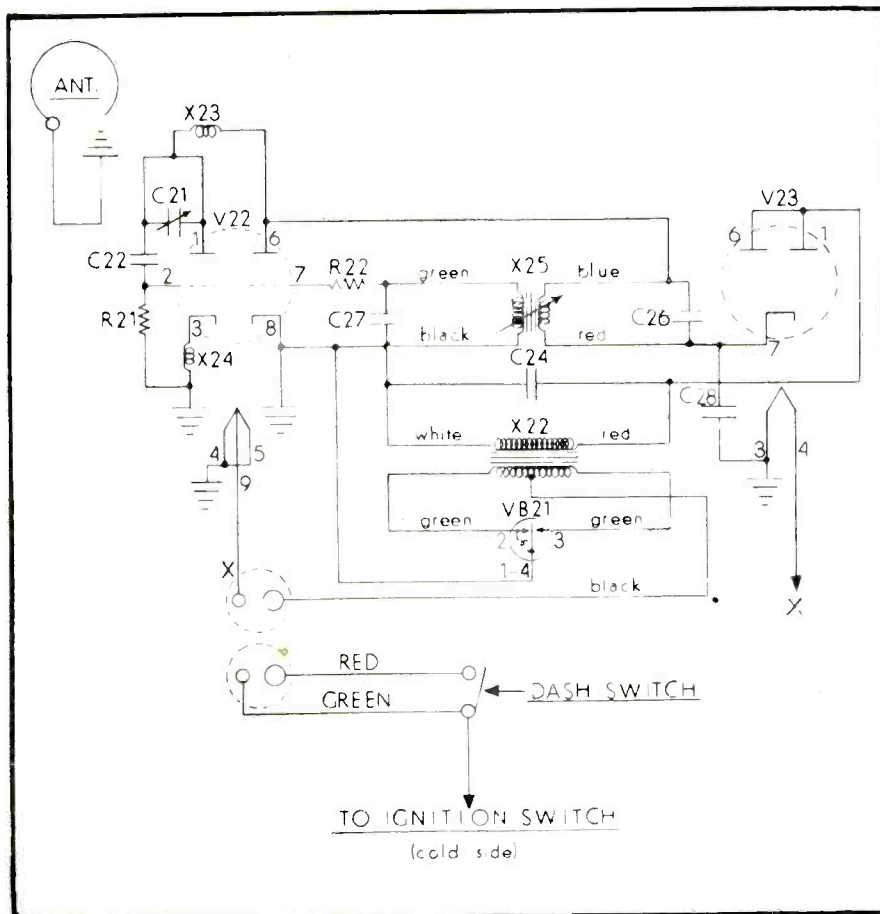

Fig. 3—Circuit diagram of transmitter unit.

New



Products



General Instrument Converter

An all-channel UHF converter called "Tuck-A-Way," was introduced by General Instrument Corporation. The new Tuck-A-Way converter can be installed behind, on either side, on top of, and, in the case of certain table models, below the television set. Unlike other converters, the dial and switch are positioned on top, making them fully accessible and easy to see in any of these positions.

Channel Master Wonder Bow

The Wonder Bow is an indoor antenna based on the same Bow-Tie and Screen principle as outdoor UHF antennas. As a result, it delivers good gain across the entire UHF band, making it a good indoor antenna for both primary and secondary UHF signal areas. On UHF its performance is comparable to conventional "rabbit-ear" types and is recommended for primary signal areas.

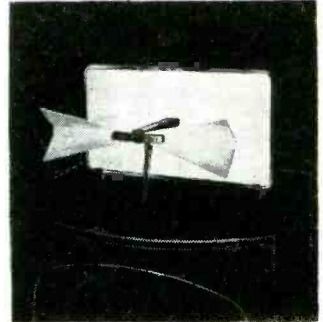

Ersin Multicore Solder

Ersin Multicore Solder, made in England, is offered in a convenient pak, on a wooden spool. Its thin wall 5 core construction assures flux continuity . . . prevents "dry" joints. Contains only Virgin tin and lead. Tin: 99.75% pure. Lead: 97.97% pure. Multicore has high grade water-white rosin, homogeneously activated. Non-corrosive even after a long exposure to humidity. It wets metal rapidly due to reduced surface tension. Vigorous fluxing action.

Cornell Dubilier "Super-Micadon"

Cornell-Dubilier has developed a midget mica capacitor in the form of an "encapsulated" unit. They occupy only about 1/3 the space formerly required for the same capacitance, and their life expectancy has also been vastly increased. Super Micadons also reveal a moisture resistance of nearly 20 times conventional types, while insulation resistance ranged from 10 times higher at room temperature to 35 times higher at + 120°.

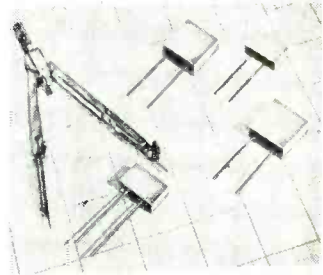

Telex Dynamic Pillow Speaker

Wide frequency and exceptional power handling ability are claimed for the Dynamic Pillow Speaker by Telex, Inc. Dynamic Pillow Speaker is housed in a stainless steel case, and the unit is edged with a shock-absorbing ring of polyethylene to withstand breakage. A long, flexible cord is detachable to permit easy cord replacement. Weight: 7 3/10 ounces. Sensitivity: Approximately 60 db above .000204 dynes per sq. cm. measured at the ear drum.

National Union Miniature CRT

National Union Radio Corporation has developed a new cathode-ray tube with a five-inch face, a heater power consumption of only 1.26 watts, and an overall length of only seven and one half inches, with special features that make it easily read in bright daylight. The tube, with a standard nine pin miniature base, uses magnetic focus and deflection and produces beam accessible and easy to see in any normal operations.

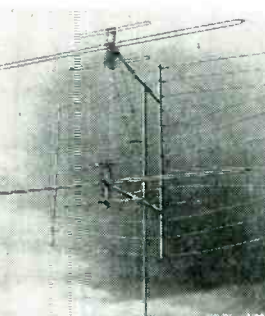
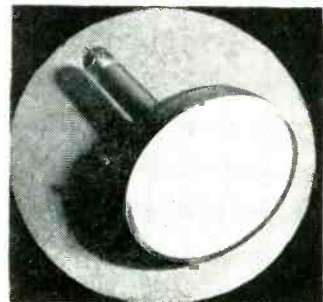

Tri-King VHF Fringe Antenna

A completely new, all-channel VHF fringe area antenna has been announced by the Clear Beam Antenna Corp. Called the TRI-KING, it is available in two models, the TK1500 for fringe area use, and the TK1800 with full 1/2 wave spacing for super-fringe area reception. The TRI-KING antenna combines a dipole assembly with a radar type, double bulls-eye reflector screen.

Snyder Dual Rear Deck Antenna

A Dual Rear Deck auto radio antenna kit is now in production at Snyder Manufacturing Company of Philadelphia. The antenna kit comes in two types, a Swivel type and a Ball and Socket type. In the former, there are models RD-8 and the RD-8B which has a matched impedance Hi-Q Transformer (Booster) for country and low signal area reception. The Ball and Socket type includes the RD-9 and the RD-9B which has the matched impedance Hi-Q Transformer (Booster).

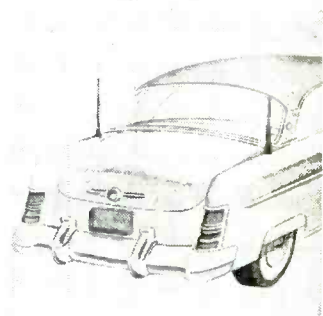

E-V Automatic FM Booster

A new Automatic FM Booster is announced by Electro-Voice, Inc. The 3005-FM Booster increases signal strength over 10 times (20 db). E-V all-electronic broadband circuit amplifies the signal at the receiver antenna uniformly throughout the FM spectrum from 88 to 108 Mc. Automatically adds gain to any channel selected on the FM receiver. Integral thermal relay is provided so that FM Booster can be turned "on" or "off" by FM receiver without any circuit modifications.

Blonder-Tongue "99" UHF Converter

Blonder-Tongue Labs of Westfield, New Jersey is now supplying a low-noise all-channel UHF Converter for class "A" signal areas. The unit is factory tested, 300 OHM impedance match throughout. The tuned input tracks with the oscillator, eliminating spurious responses and suppressing radiation. One knob precision tuning over the entire UHF band, with output to the TV set on Channels 1, 5, and 6.



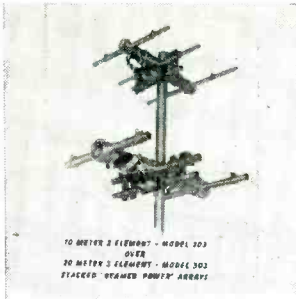

Perfect-Match Rotaries

Telrex, Inc., Asbury Park, N. J., manufacturers of "Conical-V-Beam" TV antennas, and "Beam-Power-Perfect Match" communications rotaries, announces that it has greatly expanded production facilities for rotaries for the 2, 6, 10, 15, 20 and 40 meter bands, pre-tuned for optimum gain and highest F/B and S/N ratios, which are equipped with coaxial balun and weatherproof terminal block with standard uhf connectors.



Radelco "Topper" Yagi

Radelco Manufacturing Company, Cleveland 25, Ohio, has announced the "Topper" Broad Band Yagi, Model RM-213, for areas where stations are not located in the same direction. Radelco claims that Model RM-213 gives true yagi performance on all twelve vhf channels, and fills all vhf reception requirements. Comes completely pre-assembled for easy installation.

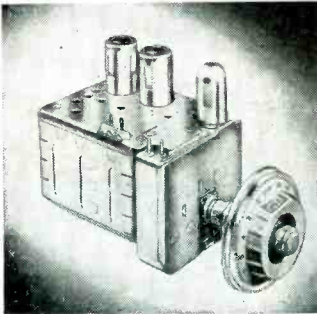

Sarkes Tarzian UHF-VHF UV-13 Tuner

Sarkes Tarzian, Inc., Tuner Division, announces a new, compact, television tuner, the UV-13, covering the full uhf and vhf bands. This tuner is actually two separate tuners mounted coaxially and plugged together to make a single, compact unit no larger than the standard vhf tuners in use today. Logical straight line electrical sequence of Compartmented circuits is the basic design feature.

Astatic UHF Converter

A new UHF Converter has been developed by The Astatic Corporation, Conneaut, Ohio. The new unit can be described as an improved, low-drift circuit using either 6T4 or 6AF4 tubes. It features a shielded tuner, affording reduced oscillator radiation, and two-stage pre-selector, providing image reflection and interference rejection. Continuous vernier tuning, at approximately 20 to 1 ratio, is featured.



Imperial 4-Conductor Lead-In

Imperial Radar and Wire has announced a 4-conductor lead-in with the following specifications: 4 strands 30%-40% copperweld 18 gauge wire with polystyrene insulators firmly embedded every 5 inches. Available on 100 foot and 250 foot spools, packed 1000 feet to the carton; and 500 foot spools packed 2500 feet to the carton.



Sylvania 302 Polymer

A new vacuum tube voltmeter, the 302 Polymer, has been announced by Sylvania Electric Products Inc. It offers a subminiature vacuum tube rf probe, a peak-to-peak scale, a new 7-inch meter movement, a lighted scale, an exclusive Sylvania patented linearity circuit, an input impedance of 17 megohms, shielded ac and rf leads and screw-on connectors. Changes in control arrangements facilitate and speed switching. These changes include a new selector switch sequence and range switches.



Windsor RADIO & TV TUBES GUARANTEED ONE FULL YEAR ... FOR PEAK PERFORMANCE!

Type	Each	Type	Each
0A2	.99	IU4	.61
0B2	.88	IU5	.51
0C3	.95	IV2	.45
1A7GT	.87	1X2A	.74
1AE4	.90	2K2	1.43
1B3GT	.69	3A5	.90
1H5GT	.51	3LF4	.76
IJ6	.93	3Q4	.66
IL4	.63	3Q5GT	.72
IL6	.66	3S4	.61
ILA4	.82	3V4	.82
ILB5	.80	3V4GY	1.00
ILB4	.82	5U4G	.44
ILC5	.80	5V4G	.83
ILC6	.80	5Y3G	.37
ILD5	.80	5Y3GT	.32
ILES	.80	5Y4G	.43
ILG5	.80	6A8GT	.68
ILH4	.80	6AB4	.51
ILN5	.80	6AC5GT	.82
IN34	.90	6AC7	.90
IN48	.50	6AF4	1.10
IN5GT	.63	6AG5	.59
IN64	.75	6AH4	.68
IR4	.85	6AH6	.89
IR5	.82	6AK5	1.45
IS4	.87	6AL5	.87
IS5	.52	6AN8	.95
IT4	.62	6AQ5	.51

Thousands of Service Organizations and Dealers send us REPEAT ORDERS month after month—they KNOW you can depend on the WINDSOR promise of PEAK PERFORMANCE. Every tube we ship is first carefully tested in our labs, for maximum functioning characteristics, right in a radio or TV Set—under actual operation conditions. Each tube is attractively packaged in the famous green and black WINDSOR carton that has earned consumer acceptance throughout America!

Type	Each	Type	Each	Type	Each	Type	Each
6A06	.47	6B17GT	.94	6SA7GT	.57	7A5	.85
6A07	.75	6BN6	.98	6SC7	.63	7A6	.62
6AR5	.42	6BQ6GT	.98	6SD7	.55	7A7	.82
6AS5	.55	6BQ7	.92	6SF5GT	.66	7A8	.56
6AS7G	4.50	6BY5G	.85	6SG7	.55	7A07	1.05
6AT6	.42	6BZ7	1.09	6SH7GT	.52	7A7F	.63
6AU5GT	.85	6C4	.44	6S7GT	.52	7AG7	.65
6AU6	.47	6C5GT	.60	6SK7GT	.55	7AH7	.65
6AV5	.85	6CB6	.58	6SL7GT	.68	7AJ7	.70
6AV6	.41	6CD6G	2.04	6SN7GT	.59	7B4	.54
6AX4	.72	6D6	.63	6SQ7GT	.46	7B5	.51
6B8G	.93	6E5	.72	6T8	.85	7B6	.52
6BA6	.50	6F3GT	.54	6U4GT	.60	7B7	.58
6BAZ	.66	6HG7	.55	6U5	.72	7C4	1.05
6BC5	.58	6J5GT	.44	6U8	.86	7C5	.56
6BD3GT	.98	6J6	.68	6V3	1.09	7C6	.50
6BD6	.54	6J7	.70	6V6GT	.51	7C7	.58
6BE6	.51	6K6GT	.45	6V6GT	.50	7E5	.85
6BF5	.66	6K7	.70	6W6GT	.63	7E6	.65
6BF6	.43	6L6G	.88	6X4	.37	7E7	.85
6BG6G	1.47	6L6GA	.88	6X5GT	.36	7F7	.69
6BH6	.63	6Q7GT	.55	6X8	.62	7F8	.97
6BJ6	.53	6R7	.75	6Y6G	.64	7G7	.85
6BK5	.76	6S4	.51	6Z5	.60	7H7	.61
6BK7	.97	6S8GT	.75	7A4/XXL	.57	7I7	.85

WINDSOR WONDER-BEAM 3-WAY TV ANTENNA



Has adjustable arms, and new electronic wonder-switch, for Maximum reception in Fringe Areas, Average Areas, and for UHF. It's a real performer—works where others fail!

SPECIAL PRICE \$5.69
Lots of Six each \$5.95 each

FREE! WINDSOR TUBE CADDY

Most practical service-aid ever designed for Radio & TV repairmen! Now offered FREE with every purchase of \$10.00 or accumulated purchases totalling \$10.00 within 90 days (You get Caddy credit memo with each purchase).

- Carries approximately 125 Tubes, including meters and tools.
- 16 3/4" long, 8 1/4" wide, 13 3/4" high. Weighs only 9 lbs.
- Ruggedly constructed with heavy leatherette covering, strong plastic handle, nickel plated hardware, and reinforced with metal clamps.

WINDSOR TUBE CADDY may also be purchased outright for \$14.95



25% Deposit with Order. All merchandise F.O.B. NYC. For orders less than \$10, add \$1 handling cost. Deduct 2% if full remittance accompanies order. All merchandise subject to prior sale and price changes without notice.

Note to our Latin-American Friends: "SE HABLA ESPANOL!"

Windsor ELECTRONIC TUBE CO.

2612-D NOSTRAND AVENUE, BROOKLYN 10, N. Y.

Type	Each	Type	Each
12BE6	.52	25AV5	.85
12BH7	.69	25BQ6GT	.98
12BY7	.77	25L6GT	.53
12J5GT	.48	25V	.51
12SA7GT	.57	25W4GT	.46
12SH7GT	.67	28Z6GT	.46
12SK7GT	.55	35A5	.55
12SL7GT	.67	35B5	.53
12SN7GT	.59	35C5	.53
12SQ7GT	.46	35D5	.53
12V6	.51	35L6GT	.52
14A7	.58	35W4	.33
14A7F	.68	35X6	.48
14B6	.50	35Z6GT	.33
14C5	.85	50A5	.55
14C7	.70	50B5	.52
14E6	.70	50C5	.52
14E7	.85	50L6GT	.52
14F7	.69	50X6	.55
14F8	.99	117Z3	.43
14J7	.85	117Z6GT	.75
14N7	.75		
14Q7	.62		
14R7	.85		
14S7	.80		
19BG6G	1.53		
19T8	.87		

WINDSOR BROW-LITE



Leaves Both Hands Free To Work!

Ideal for Radio & TV Repairmen! Puts light right where you need it. Uses standard pentode batteries and bulb. Does not interfere with glasses, rides over the brow. Order yours TODAY... you'll never want to be without it!

Complete with Batteries **\$4.95**

WRITE FOR ADDITIONAL TUBE TYPES AND PRICES. We also stock Special Purpose and Transmitting Tubes at similar savings! Dept. D-7

Dictate Reports Accurately-Promptly!

**make your car,
boat or plane
a "rolling
office"**

with



INVERTER

for changing your storage battery current to A. C. Household ELECTRICITY

Anywhere . . .

in your own car!!

ATR INVERTERS . . . especially designed for operating standard 110 volt A. C. . . .

- TAPE RECORDERS
- WIRE RECORDERS
- DICTATING MACHINES
- ELECTRIC RAZORS

for

- EXECUTIVES
- SALESMEN
- PUBLIC OFFICIALS
- POLICEMEN
- FIREMEN
- OUTDOOR MEN
- REPORTERS
- FIELD INSPECTORS
- DOCTORS
- LAWYERS, ETC.

See your jobber or write factory

NEW MODELS ✓ NEW DESIGNS ✓ NEW LITERATURE
"A" Better / Eliminators, DC-AC Inverters, Auto Radio Vibrators

AMERICAN TELEVISION & RADIO Co.

Quality Products Since 1931

SANIT PAUL 1, MINNESOTA—U. S. A.



mounted out of sight under dash or in trunk compartment!

**EASY TO INSTALL
EASY TO OPERATE**

TV INSTRUMENT CLINIC

[from page 7]

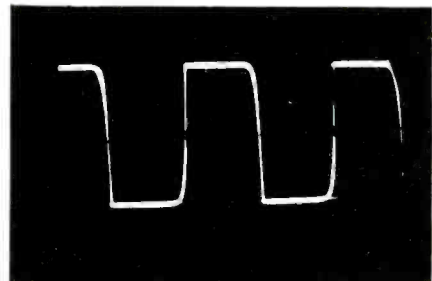

Fig. 8 — Vertical gain increased.

A. A typical situation of jitter is shown in Fig. 9. In this case, the positioning voltage on the horizontal deflecting plates of the cathode-ray tube varied as a result of line-voltage fluctuation. The difficulty can be cured by operating the scope from an automatic line-voltage regulating transformer.

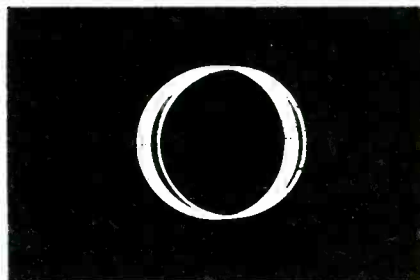

Fig. 9 — Horizontal jitter.

Q. What is the purpose of a white-dot generator in color-TV servicing?

A. A white-dot generator is used to adjust for proper convergence. Fig. 10 shows the output from a white-dot generator: a polarity switch must be

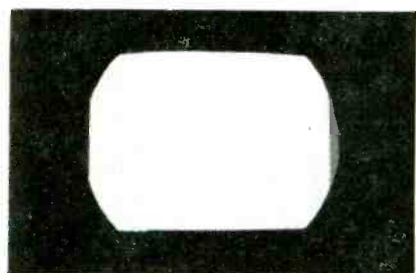

Fig. 10 — White dot gen. pattern.

used to obtain white dots, since the black dots illustrated will be obtained when the output polarity is unsuitable. It is also desirable that the dots be reduced in size to the point that brightness begins to be impaired.

TRADE FLASHES



RETMA reports that radio set shipments to dealers during March increased substantially from the February level, bringing the total for the first quarter of 1954 to nearly one million.

Nearly two million television receivers and over three and one-quarter million radios were manufactured during the first four months of this year. Average weekly production of both products remained at approximately the level of March.

Manufacturers' sales of receiving and cathode ray tubes in March increased from the level of February but remained below March 1953, the Radio-Electronics-Television Manufacturers Association reported today.

Over 120,000 more television sets were shipped to dealers in February than had been shipped in March, bringing the first quarter total to nearly 1.7 million.

Manufacturers' sales of receiving tubes in April showed an increase for the fourth consecutive month while cathode ray tube sales declined slightly from the March level.

Television service dealers and technicians were offered without charge a color television receiver home study course with their purchases of specified quantities of RCA receiving tubes. The promotion is sponsored by the Tube Division, Radio Corporation of America, and will be conducted through RCA tube distributors. The nine-lesson course will be provided dealers on the basis of RCA receiving-type electron tubes purchased from RCA distributors between May 1 and November 15, 1954, Mr. Bersche said. The course was prepared by RCA Institutes, Inc., the RCA Laboratories Division, and the RCA Service Company. It covers all phases in the principles and servicing of home color television sets.

"Large screen Du Mont color television picture tubes will be available for use in television receivers by the Fall of this year", it was announced today by Bill C. Scales, General Sales Manager of the Cathode-ray Tube Division of Allen B. Du Mont Laboratories, Inc.

"Receiver manufacturers will be getting deliveries of Du Mont's 19-inch 'Chroma-Sync Teletron' in time for incorporation in the receivers they will

3 SHURE CRYSTAL PICKUP CARTRIDGES *replace the 192*

cartridges you are most likely to encounter
in your service work!

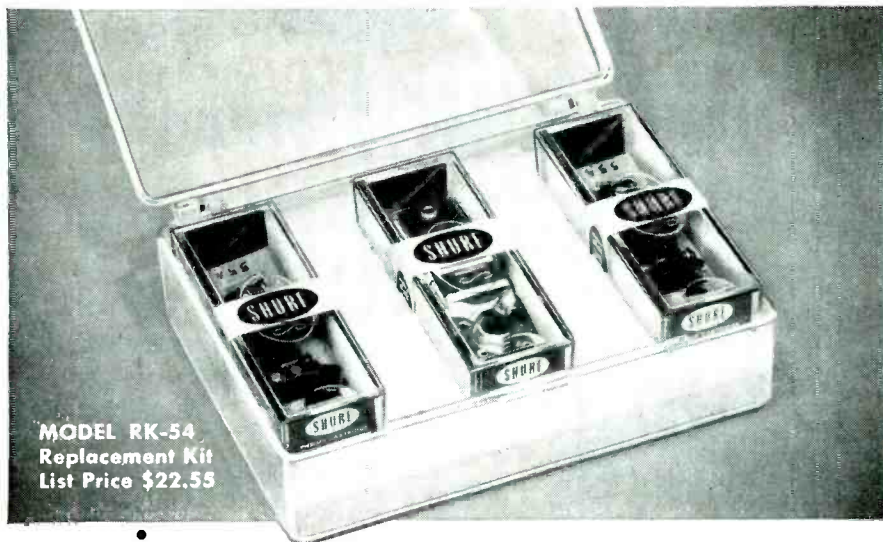

MODEL RK-54
Replacement Kit
List Price \$22.55



TECHNICAL DATA AND REPLACEMENT CHART IS ENCLOSED.
Lists 192 Crystal Cartridges manufactured by
five leading cartridge manufacturers.

Lowest investment for broadest coverage! The RK-54 is beyond all doubt the *most practical* Replacement Kit on the market! Proof? Simply this—you get the broadest coverage at the lowest investment—only \$22.55 list! Think of it—3 Crystal Cartridges replace 192 of those specific Cartridges most likely to be in need of replacement! Two of the Cartridges consistently have been "best sellers" in the Shure line—as established by actual sales to Servicemen! The Cartridges are: Model W22AB, 3-Speed, 2-Needle Cartridge—Model W26B, All-Purpose, Single-Needle Cartridge—Model W78, 78 RPM, Dual-Volt, Dual-Weight Cartridge. Model W78 is the new, versatile Cartridge that replaces 149 other Cartridges! This Cartridge alone will become a sensation overnight! Order a Replacement Kit from your Distributor today—once you have worked with this practical kit you will find that these three Cartridges are dependable replacements—will make your service work faster, easier and more profitable!



TRANSPARENT PLASTIC BOX IS FREE!

This Handy Box is 5" long, 3½" wide,
1¼" deep.

SHURE — *The Mark of Quality*

THANK YOU, Mr. Serviceman

for naming



your preferred brand!

In a recent nationwide survey*, radio and TV servicemen were asked this question: "What brand of replacement speakers do you prefer? Why?" QUAM was first in number on mentions—almost 30% more than the next most preferred brand.

* Conducted by Brand Name Surveys of Chicago, Illinois, May 1954.

WHY?
here are some typical comments about QUAM speakers by these servicemen

- "Adjust-a-Cone feature-ruggedness"
- "Complete range of sizes and types"
- "Stand up best in service"
- "Include hardware for easier installation"
- "Good construction"
- "Listed in Sams' Photofacts"
- "Heavier magnets"
- "Good quality at a reasonable price"
- "Always satisfactory"

ask for **QUAM** the quality line, for **ALL** your speaker needs

QUAM-NICHOLS COMPANY

238 EAST MARQUETTE ROAD • CHICAGO 37, ILLINOIS

TRADE FLASHES

[from preceding page]

be marketing during this year's pre-Christmas selling season", Mr. Scales went on to say. He made the announcement at a two-day meeting, May 10th and 11th, conducted by Du Mont for manufacturers of television receivers and other manufacturers of television picture tubes.

A contract has just been signed by John F. Rider, Publisher, 480 Canal Street, New York City, and Van Valkenburgh, Nooger, & Neville, Inc., 15 Maiden Lane, New York City, which will release to the commercial civilian market a course of instruction in Basic Electricity and Electronics, originally developed for the program of the Bureau of Naval Personnel which is now established in authorized Naval electrical and electronic specialty schools.

To develop the program, the Navy employed not just one or two authors, but an entire staff of training specialists, the graphological engineering firm of Van Valkenburgh, Nooger & Neville, Inc. Theirs is one of the newest forms of professional activity, and their specialty is the preparation of entire packaged training programs. The graphological boys have done their job well in this case, establishing a common core of subject matter, translating it into a course of study, and incorporating the best of current thinking in training methods and techniques.

The Government is seriously concerned about the selenium situation, and the President has approved stockpiling for military requirements in the event of a national emergency. This will cut into a supply already reduced by a reduction in copper production. Reclamation of selenium from replaced rectifiers is at least a partial and immediate solution to the problem, and the Sarkes-Tarzian Rectifier Division of Bloomington, Indiana, has published an open letter to all servicemen requesting their cooperation in returning replaced rectifiers for credit, to the distributor, who is then credited against purchases by the Sarkes-Tarzian Division at the rate of 2½ cents each on rectifiers rated at 65 to 150 milliamperes and 5 cents each on rectifiers rated a 200 milliamperes or more. Cooperation is vitally needed to insure a continuous supply of replacement rectifiers. A reduction in production would lead to either rationing or the requirement that a replaced rectifier is supplied for each new one purchased.

Faster, Easier, more PROFITABLE Operation

Get into the MASTER habit!

Brings you the product data of the industry in one handy book—all products vital to your daily sales and service operations. In the customer's home, across the counter or on the bench, you'll value the MASTER'S thoroughly complete descriptions, specs, illustrations and prices . . . all systematically organized in 18 big sections. Over 1300 pages of unabridged catalog data direct from the manufacturers. Keeps you abreast of all latest electronic products. Increase your sales and speed-up your buying—the MASTER way.

As **\$1.95** at your parts distributor. Publisher's price **\$6.50**.

OFFICIAL BUYING GUIDE OF ELECTRONICS-TV-RADIO INDUSTRY

• 1370 pages
• 8" x 11"—5 lbs.
• Over 8,000 illus.

Just a few of the more than 85,000 items included:

Tubes—Transmitters
Test Equip.—Receivers
Transformers
Capacitors—Antennas
Resistors—Wire & Cable
Coils & Relays
Recording & PA
Hardware & Tools

Get your MASTER now from leading parts distributors or write to:
United Catalog Publishers, Inc., 110 Lafayette St., N. Y. 13

Eliminates Small Catalogs and Loose Literature

ASSOCIATION NEWS

CRTSA—Philadelphia

The Council of Radio and Television Service Associations met to study and act on its many committee reports concerning the local radio and television service industry. Among these were a financial report on the Color Symposium recently held, which showed that the Symposium was a financial success and that funds left will be used to promote the new Public Relations program and technical meetings for the membership.

TISA—Chicago

What is the truth about TV? How often does it require service? What can go wrong? How much should it cost? How long should a picture tube last? When can color TV be expected? How big will the picture be? How much will it cost to maintain a color TV set? The problem of disseminating this information is tough.

To solve this problem, the Television Installation Service Association (TISA) has created a lecture bureau fully qualified to address any civic, religious, fraternal, PTA, or business group giving a thorough analysis of the owners' TV problems. Any group desiring this program at no cost whatever should communicate with TISA headquarters at 5908 S. Troy St., Chicago 29, Ill.

ETSC—Philadelphia, Penn.

The Committee on Service and Association Problems, of the Eastern Television Service Conference, Inc., held in Philadelphia, Pa., in April, 1954, recommended that the Eastern Conference and member associations sponsor a "TV Trouble-Prevention Month" not later than May 30 each year, with TV, radio, and newspaper publicity, to bring to the attention of TV set owners the advisability of an annual check up on their receivers, antennae, and associated equipment. They also recommended that those few member associations which do not now have a written Code of Ethics adopt and subscribe to such a code as soon as possible, and that self-policing of the television service industry at the local level be encouraged. They condemn all misleading advertising, false claims, and trick approaches on the part of any TV serviceman, and believe that one of the greatest services local associations can perform for their

more servicemen prefer

STANCOR

REPLACEMENT TRANSFORMERS

than all other brands combined*

because they like the . . .

- ease of installation
- completeness of the Stancor line
- availability of accurate replacement information
- rugged, breakdown-proof construction
- quick delivery from distributor's stock

Brand Name Surveys, Chicago, Illinois: brand preference survey of electronic replacement components, May, 1954. Answered by servicemen from all over the U.S.

FREE NEW STANCOR GENERAL CATALOG listing over 500 transformers for TV, radio, high fidelity, communications and other electronic applications. Available from your local Stancor distributor or by writing Standard Division, Chicago Standard Transformer Corporation.

Stancor transformers are listed in Photofact Folders and Counterfacts

CHICAGO STANDARD TRANSFORMER CORPORATION

3586 ELSTON AVENUE • CHICAGO 18, ILLINOIS

EXPORT SALES: Roburn Agencies, Inc.
431 Greenwich Street, New York 13, N. Y.

members at this time is the presentation of reliable color-service training programs for their members. They also urged member associations which issue publications to chose advertisers in their publications carefully, and warn such publications that criticism of a competent fellow technician is a double-headed snake which will strike the accuser as well as the accused.

ESA of Detroit

The announcement has been received of the formation of a new service association in the Detroit area. The Electronic Service Association has been organized as a non-profit organization under the laws of the State of Michigan and is open to anyone engaged full time in the servicing of radio, television and electronic equipment. The officers for the coming year include:

President, Ralph L. Carew, University Radio & TV; Vice President, Joseph Rosson, Colonial Dept. Stores; Recording Secretary, George Sturman, Sanders Electronic Service; Treasurer, Peter Wroblewski, Parkside Radio & TV; Corresponding Secretary, T. T. Czarnecki, Marx TV-Radio. Educational meetings and service clinics are being planned for future meetings as well as other activities of general interest to the servicing industry in this area.

TSDA of Philadelphia

Television Service Dealers Association of Philadelphia held its monthly business meeting on May 21st.

The Legal Counselors for TSDA reported and read the new proposed Anti-Bait Advertising Bill drafted by the Counselors for the association to present

FOR GREATER PROFITS

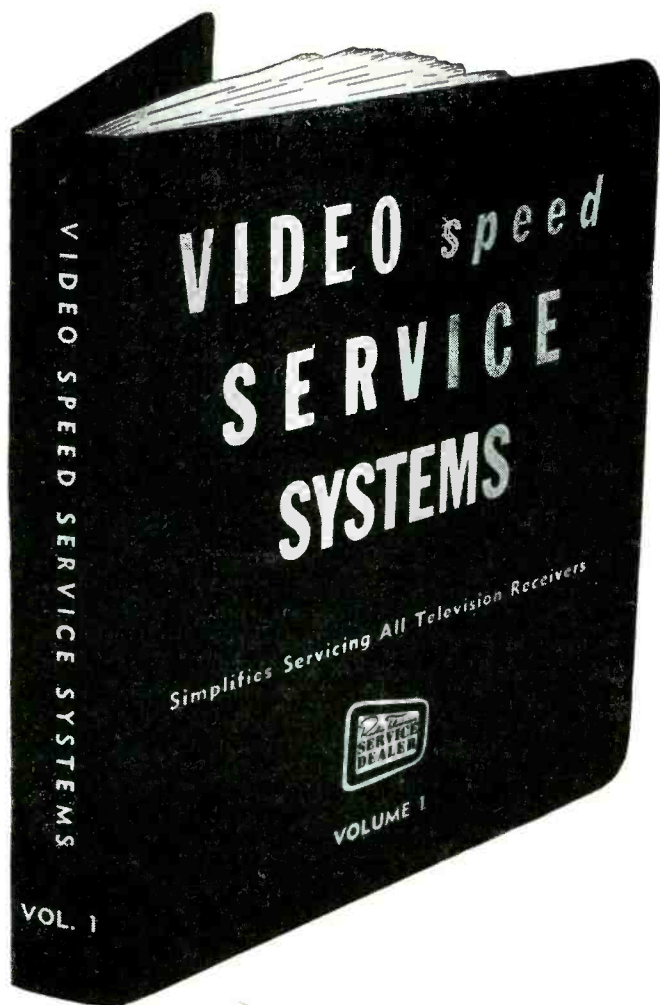

SPEED UP YOUR SERVICING with THIS NEW BOOK

which shows you how to take care of and repair in the quickest possible time:

- Common troubles characteristic of certain receivers
- "Bugs" which might take you hours to find
- Factory and field service changes

SET UP SO THAT YOU CAN MAKE THESE REPAIRS IN THE SHOP OR IN THE FIELD WITHOUT REFERENCE TO ANY OTHER SOURCE.

Contains over 600 Service Items representing over 1000 of the most-serviced Television models now in use. Over 25 different manufacturers' lines are covered.

\$4.95 postpaid

(Add 3% Sales Tax in New York City)

DISTRIBUTORS—ORDER YOUR SUPPLY NOW!

Service Dealers—get your copy of VSSS from your Distributor. If he can't supply you, order direct by mail from us.

Video Speed Servicing Systems IS GUARANTEED to Simplify Servicing All TV sets. A number of new Data Items are published in every issue of "Radio-Television Service Dealer" as a regular monthly feature.

TEAR OFF AND MAIL NOW

RADIO-TELEVISION SERVICE DEALER

67 West 44th Street, New York 36, N. Y.

Please send me post-paid VIDEO SPEED SERVICING SYSTEMS Volume 1. Enclosed herewith is

my check money order for \$_____ for _____ copies at \$4.95 each. (Add 3% Sales Tax in New York City)

Name

Address

City Zone State

to the City Council for approval and adoption as an ordinance. This Bill was unanimously approved by the Membership. Reports were made by the Judiciary Committee of progress in their investigation of Bait ads by part time operators and unethical service com-

panies. This committee has now arranged for a series of meetings with representatives of the Mercantile Licenses & City Tax Dept., State Sales Tax, Zoning Committee and Better Business Bureau to check on and investigate the committee findings.

LICENSE BILL

[from page 24]

either in person or by counsel, any license issued under this article may be revoked or suspended. * * * What is meant by a "verified complaint" is a complaint reduced to writing and sworn to or before a Notary Public or other officer qualified to take oaths. It is by this provision that the Secretary of State has power to revoke or suspend the serviceman's license. Without a license he cannot continue in business. The section further provides for a review of the action of the Secretary of State "pursuant to * * * article seventy-eight of the civil practice act." This would be a judicial proceeding before the Supreme Court wherein the revocation or suspension might be overruled if found to be arbitrary or capricious. The bill further provides for restoration of the revoked license after the period of

one year upon prescribed terms. In the last section, the bill provides that "Any person who violates any provision of this article shall be guilty of a misdemeanor and shall be punished by a fine of not more than five hundred dollars or by imprisonment for not more than ninety days, or both such fine and imprisonment." A misdemeanor is a crime. Violation of the law would consist of operating in business without a license or of breaching any of the rules or regulations created by the Secretary of State. Such violation could result in the arresting or summoning of the serviceman and his prosecution in one of the lower criminal courts. On conviction, the sentencing judge would have power to impose punishment of up to ninety days imprisonment and a fine of five hundred dollars.

ANSWER MAN

[from page 13]

most often alleviate or reduce the whistle. It may be found that just loosening the mounting screws will be sufficient to affect a remedy. If this does not improve the reduction of sound, the screws may be tightened with care. Do not fasten the screws on any transformer too tight or the powdered iron core may crack or break.

Some technicians have wedged pieces of material between the windings of the horizontal output transformer and the core; however better still is the pouring of insulation compound between the core and the transformer which is more often successful. Of course, the insulation compound should be of the high voltage type.

After all possibilities have been exhausted it may be found necessary to replace the horizontal output transformer to eliminate all traces of the high pitched whistle from some TV receivers. In this case the replacement should be one of the newer types which are not so prone to develop this condition.

Selenium Rectifiers

Dear Answer Man:

We seem to be having a considerable amount of trouble with selenium

rectifiers. Why doesn't the manufacturer of TV receivers go back to the old standby, the 5U4 vacuum tube or its like. This was an excellent arrangement and did not present as many difficulties in servicing.

L. F.
Hicksville, L. I.

Dear L. F.:

Selenium rectifiers are unquestionably a step forward in the design of television receivers and they will certainly be used more in other types of electronic equipment. They have many advantages over the old system of power transformers and rectifier tubes such as better regulation with a reduction in weight of the chassis. If an overall comparison were to be made between selenium rectifiers and vacuum rectifier tubes it would be found that the use of selenium rectifiers is advantageous.

The major difficulty seems to arise out of the fact that some technicians replace selenium rectifiers with others of too small a size, such as replacing a 350 ma selenium with a 300 ma selenium rectifier.

It is generally advisable to use a selenium rectifier that is rated at least at



THE
American
IDEA



"To find and follow the better way"... Gigantic offspring of the cyclotron, the Bevatron—world's greatest magnet—can send masses of protons hurtling around its 135'-diameter race track at almost the speed of light. "Idea", to penetrate deep into the atomic nucleus, where lie secrets of matter and energy.

With us, the "American Idea" is, by directed effort and applied know-how, to continue to lead in bringing you electronic products of the highest quality.



Complete line of "Full Vision" Microphones
D33 Broadcast
D-22 Public Address

Replacement Phonomicrophone Cartridges

INSIST ON AMERICAN FOR QUALITY
Send for FREE Catalog 47



American microphone co.

370 South Fair Oaks Ave. • Pasadena, 1, Calif.

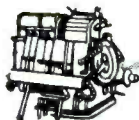

JUST OFF THE PRESS!

1954 CLAROSTAT CATALOG

Packed with data on standard radio and electronic controls and resistors. Concise descriptions . . . photo illustrations . . . dimensional drawings . . . listings . . . prices . . . standard packings. Also the new C-Line and other "industrial" controls.

For the latest in controls and resistors, be sure to include this latest literature in your data file.



Ask your Clarostat distributor for your copy of Clarostat Catalog No. 54. Or write us.



Controls and Resistors

CLAROSTAT MFG. CO., INC., DOVER, N. H.

In Canada: CANADIAN MARCONI CO., LTD., Toronto, Ont.

LABORATORY DESIGNED for UHF and VHF! ... It's NEW!

MOSLEY 2-WAY TV ANTENNA SWITCH

- Extremely low Standing Wave Ratio — by actual test!
- Positive rotary action!
- Silver-to-silver contacts!
- Compact size!
- Solderless — easy to install!
- Low cost!

Cat. No. F-40 List Price \$1.95

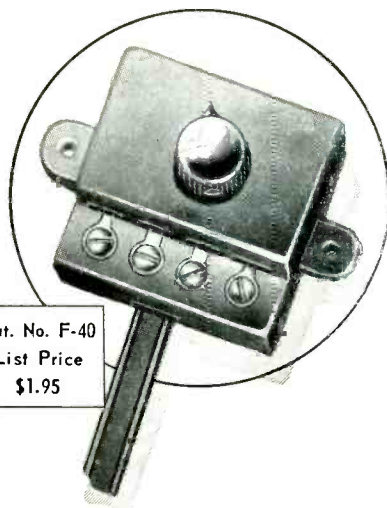

Mosley Electronics, Inc. 8622 ST. CHARLES ROCK ROAD ST. LOUIS 14, MISSOURI

Another PREMIUM QUALITY MOSLEY Accessory for BETTER TV INSTALLATIONS!

Give the United Way!

450 ma in a television receiver. Although seleniums with lower ratings will certainly hold up if the manufacturer originally used that size, the small additional cost to the customer of installing a larger rectifier will generally be worth while.

Along these lines some TV manufacturers have gone as far as to suggest to servicing technicians that they use only 450 ma replacements even though the original selenium rectifier was rated at 350 ma. The only difficulty that might be encountered in some receivers in the installation of 450 ma selenium rectifiers is physical size. In some cases the 450 ma replacement just won't fit in the space provided, in which case the serviceman usually takes the easiest way out and leaves one of the original size in.

Selenium rectifiers have been blamed for performing worse than vacuum tube rectifiers under varying line voltage conditions. However, there is little evidence to support this claim.

COLOR

[from page 10]

ment voltage is provided by a single turn winding on the horizontal output transformer.

In the high voltage rectifier circuit, C2 acts as a battery in series with the pulse voltage applied by the transformer to the high voltage doubler tube T3. These two voltages add up to the total voltage supplied to the last rectifier tube and a doubling action is accomplished.



Fig. 23 — The 3A3 high voltage rectifier tube, used in color TV.

Tubes used in the high voltage section are the 3A3 (Fig. 23) which is a high voltage pulse rectifier or coupler tube and the 1X2B tube which is also designed for high voltage coupler use. The 3A3 tube is of the directly heated cathode type. Its base fits the standard octal socket, the connections of which are shown in Fig. 24. Filament voltage of 3.15 volts is supplied by a horizontal output transformer filament winding. The peak inverse plate voltage that the tube can withstand is 30,000 volts.

[Continued on page 48]

TRADE LIT *Check List*

Aside from the books reviewed in our Trade Literature columns, many valuable bulletins, catalogs, guides, etc. are made available by manufacturers, etc. at no cost, or in some cases, nominal cost, to the servicing profession. As an aid to the busy technician, RTSD publishes this Check List. To the best of our ability, the items are listed in the order in which we learned about them. This, we feel, is the fairest and most sensible way to help the serviceman keep up with things. Items that couldn't make the list this month because of space limitations will ride at the head next issue. Unless otherwise specified, all literature pieces in the Check List are free for the asking. Simply write to the organization listed in the Source column, and mention you saw it in *Service Dealer*.

LITERATURE AVAILABLE

Astron's new 48-page **Capacitor Catalog** shows latest available types, and tech data on electrolytic, paper-foil, and metallized-paper capacitors. They have arranged paper foil and metallized-paper units according to temperature and performance characteristics as well as by case types.

The distributors **Confidential Picto Price Schedule No. 400-A**, published by JFD Mfg. Co., Inc., encompasses an extensive line of TV antennas, listing latest price cuts in each item, plus numerous new developments.

Weston presents their new "980" line of **TV test equipment** in a six-page brochure, in which are described new, time-saving methods of alignment.

A new **Catalog**, by Channel Master Corporation, illustrates and describes both *vhf* and *uhf* antennas, masting, towers, mounts, inter-action filters, and general accessories.

James Vibrapower Co. has issued a new **Vibrator Replacement Guide** incorporating a complete post-war cross reference of auto replacement, communications and aircraft equipments using vibrators.

Columbia Wire and Supply has issued a 36-page, multi-colored **Catalog** introducing many new items with complete technical data.

Shure's revised **General Catalog No. 44B** contains illustrations and data on Shure microphones for all applications; mike accessories, tape and wire recording heads, pickup cartridges, and needles.

The **GE Booklet ETR-866** lists receiving and cathode-ray tube types for AM, FM, and TV receivers in tabular form, including characteristics charts and interpretation of tech data.

TACO has issued a new **Catalog** arranged to include only those antennas and accessories specifically designed for the area served by the distributor and his dealer. Individual sheets featuring each antenna give full technical info.

J. W. Miller has just released their **Catalog No. 55**, a 32-page book containing many hundreds of items in the radio and TV coil line, for both broadcast and reception applications.

The 1954 **Stancor TV Transformer Replacement Guide** contains replacement data on over 6800 TV models and chassis of 115 manufacturers, including info on many "private label" sets.

The **Permo, Inc. Catalog for 1954-55** refers to tape and wire recording, a cross reference of needles, a listing of conventional type needles, replacement needle shape chart, needles by cartridge and number, and an "industry wide" cross reference needle guide.

RMS has issued two new catalogs: **55-S**, which describes and illustrates the latest RMS antennas and accessories, and **55-II**, which details the complete line of hardware available through RMS distributors.

SOURCE

Astron Corp.
255 Grant Ave.
E. Newark, N. J.

JFD Mfg. Co., Inc.
6101 16th Ave.
Brooklyn 4, N. Y.

Weston Electrical Instrument Corp.
614 Frelinghuysen Ave.
Newark 5, N. J.

Channel Master Corp.
Ellenville, N. Y.

James Vibrapower Co.
4036 N. Rockwell St.
Chicago 18, Ill.

Columbia Wire and Supply Co.
2850 Irving Park Road
Chicago 18, Ill.

Shure Brothers, Inc.
225 W. Huron St.
Chicago 10, Ill.

General Electric Co.
Advertising Inquiry
Electronics Park
Syracuse, N. Y.

Technical Appliance Corp.
Sherburne, N. Y.

J. W. Miller Co.
5917 So. Main St.
Los Angeles 3, Calif.

Chicago Standard Transformer Co.
Addison and Elston
Chicago 18, Ill.

Permo, Inc.
6415 N. Ravenswood Ave.
Chicago 26, Ill.

Mr. Clifford Shearer
Director of Advertising
RMS
2016 Bronxdale Ave.
New York 62, N. Y.



you're on *easy street*
with **PHOTOFACT**

TUBE PLACEMENT and TUBE FAILURE CHECK CHARTS

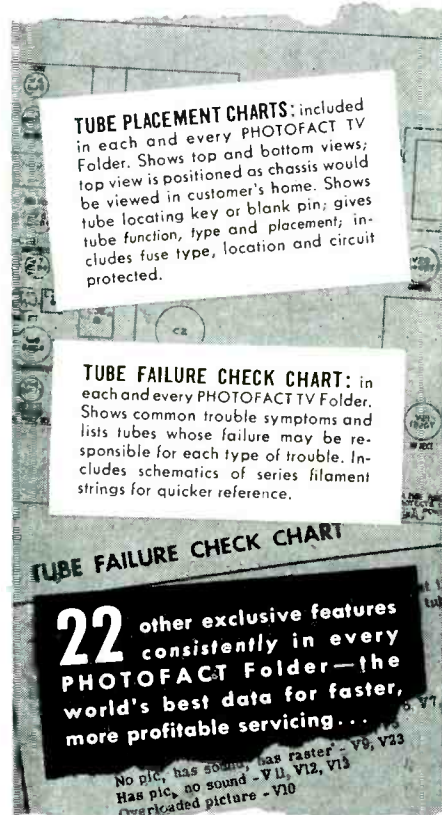

NOW! GET THE PROOF FOR YOURSELF!

FREE We'll send you a Free Photofact TV Folder—just ask us for it!

Learn for yourself how PHOTOFACT pays for itself by earning bigger profits for you! We'll send you the proof—a FREE specimen PHOTOFACT TV Folder that shows all the features found consistently and exclusively ONLY in PHOTOFACT. Send for your FREE specimen TV Folder now. Examine it. Compare it. You'll see why PHOTOFACT belongs in your shop! And you'll want to ask your parts distributor about the pay-as-you-earn-plan. Only \$25 down brings you the entire PHOTOFACT Library. Write for FREE specimen TV Folder—learn now how to earn more!

HOWARD W. SAMS & CO., INC.
2209 E. 46th St., Indianapolis 5, Ind.
HOWARD W. SAMS & CO., INC.

2-Year Subscription only \$1.00



NOW AVAILABLE TO . . .

1. Servicemen who are employed by Service Organizations.
2. Servicemen employed by radio/TV Dealers.
3. Independent servicemen who do not have business establishments.
4. Employees of Distributors.
5. Students enrolled in accredited Radio/TV Schools, Colleges, etc.
6. Hobbyists and Experimenters.

A TYPICAL ISSUE COVERS

- Video Speed Servicing Systems
- Rider's "TV Field Service Manual" data sheets
- Latest TV Installation and Maintenance Techniques for VHF and UHF
- Auto Radio Installation and Service
- Advanced Data on New Circuitry
- Production Changes and field service data on receivers
- New Tubes
- New Test Equipment, operation and application
- Hi-Fi Installation and service
- New developments, such as transistors, color, UHF, etc.
- News of the trade
- Service Short Cuts & Shop Notes
- Explanation of difficult circuits

**and many more
EXCLUSIVE . . .
ORIGINAL . . .
AUTHORITATIVE . . .
TIMELY . . .
FULLY ILLUSTRATED
subjects that
can ONLY
BE READ IN
"SERVICE DEALER"**

RADIO-TV SERVICE DEALER
67 W. 44 St., New York 36, N.Y. NEW RENEWAL

Gentlemen: Here is \$1.00 for which enter my 2-year subscription. (This rate applies in USA only. Elsewhere add \$1 per year)

Name

Address

City Zone State

Employed by (Name of firm)

Firm's business address

City Zone State

Your Position or Title

Check whether firm is: Service Organization or Dealer having Service Dept.

If some other type of company describe:

IF STUDENT, Name of School

WORK BENCH [from page 21]

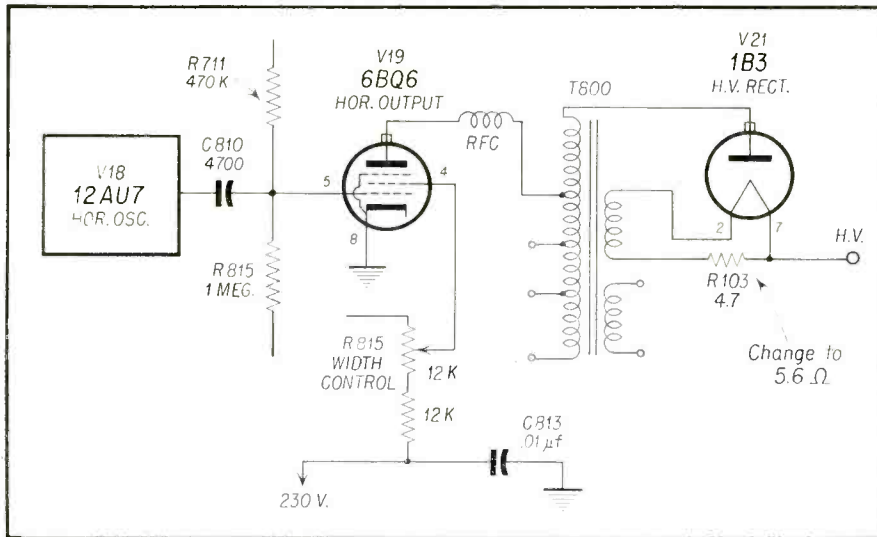

Fig. 3 — Partial schematic, high voltage section Philco 1954 "B".

approximately 285 kc. A high *rf* voltage is developed across the resonant high voltage coil. This voltage is coupled to the plate of the 1B3 where it is converted to pulsating *dc*. On this same core is a filament winding for the 1B3. Due to the relatively high frequency the filtering network is simplified to C504, B504, C505. See Fig. 4.

Knowing these facts, a check was made to see if the 6V6 was oscillating. A voltage measurement was taken from Pin 25, the control grid, of the 6V6 to ground. A negative reading of a few volts would be an indication that it was oscillating. However, the meter read about zero. The plate and screen voltage was measured and was found to be slightly off by a few volts.

Next, a continuity check of all of

the windings of the high voltage coil was taken, and none of them were found to be open. All components in the high voltage section were then checked and found to be okay.

As a last resort, before replacing the high voltage coil, a resistance check of the windings was made against another high voltage coil which we had in stock. All of the windings were found to check fairly close except the oscillator plate winding across which was C506, the oscillator trimmer. The winding read practically zero ohms. Clipping C506 out of the circuit brought the resistance reading back to normal. Thus, the shorted C506 was replaced and adjusted for maximum high voltage (maximum brightness) and the receiver now functions properly.

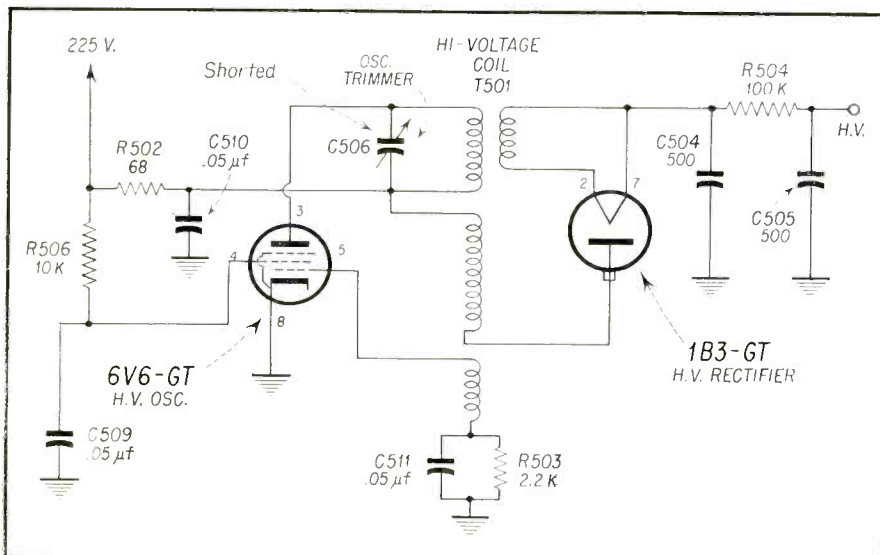
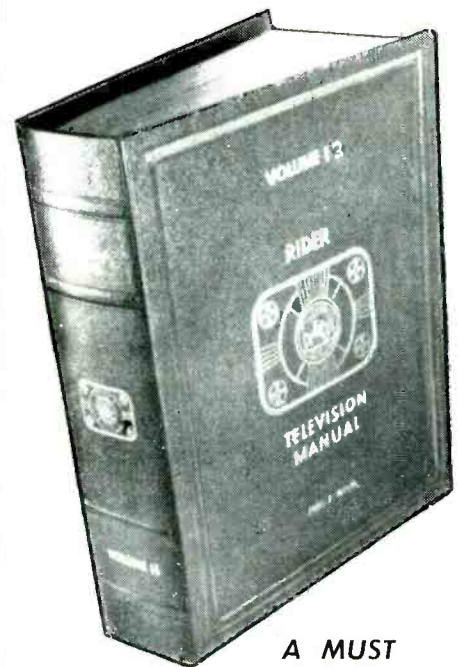

Fig. 4 — Partial schematic, high voltage section Westinghouse V-2150-01.

RIDER'S TV-13

with replacement parts listings . . .
INCLUDES MAY 1954
FACTORY DATA



A MUST FOR THE WELL-RUN-SHOP

JUST OUT—The latest up-to-the-minute production and service information—right up thru May 1954. Nothing else this current, this complete on the market!

COLOR TV SERVICING — Factory-prepared data on servicing RCA COLOR TV receivers.

MANUFACTURERS—Full data on more than 50 manufacturers of TV receivers—covers service calls for any make set.

FACTORY-AUTHORIZED—Every fact guaranteed to be factory-authorized—you get the whole story from the one who knows it best!

COMPLETE—In one package you get the latest Chassis Views . . . Schematics . . . Waveforms . . . Circuit Changes . . . Replacement Parts Listings . . . Production Run Changes! And there is a complete, cumulative index of RIDER'S TV MANUALS 1 thru 13—quick, easy reference to previous servicing data!

DURABLE BINDER—Add this hard-cover manual to your permanent servicing bookshelf—the durable cover keeps your data together—no loose pages to get lost. Absolutely the most authoritative, complete, and up-to-date servicing manual available! Contains the equivalent of more than 2,300 (8 1/2 x 11") pages

only \$24.00

ORDER FROM YOUR JOBBER TODAY!

Write for complete 32 page

NEW RIDER CATALOG

Write for information on all RIDER books. Buy these books now from your jobber . . . bookstore . . . If not available from these sources, write to:

JOHN F. RIDER PUBLISHER, INC.
480 Canal Street, New York 13, N. Y.

Snyder
PHILADELPHIA

**AUTO
RADIO
ANTENNAS**

**THE
ONLY
COMPLETE
LINE**

SNYDER

SNYDER MFG. CO., PHILADELPHIA 40, U.S.A.
BELLEVUE TUBE MILL, INC., PHILADELPHIA
SNYDER ANTENNA ENGINEERS LTD., TORONTO 14
WORLD EXPORT: ROBURN AGENCIES, INC., N.Y.



COLOR

[from page 44]

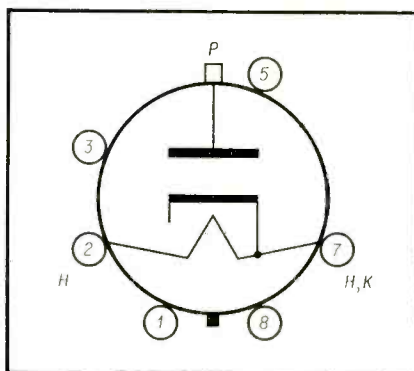

Fig. 24 — Tube base connections of 3A3 rectifier tube. Pins 1, 3, 5 and 8 are internal connections to tube elements but they are not to be used as connections. The base pins of the 3A3 fit the standard octal socket.



Fig. 25 — 3A2 high voltage rectifier tube used in color TV.

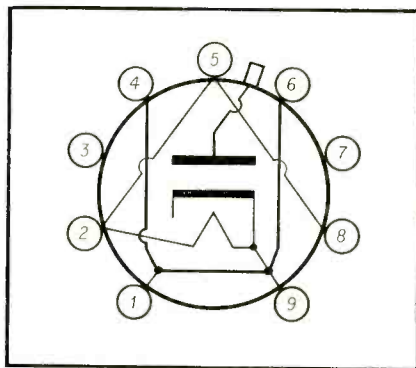

Fig. 26 — Tube base connections of 3A2 rectifier tube. The base pins fit the standard 9 pin noval socket universally used.

Also used in high voltage color rectifier circuits is the 3A2 (Fig. 25) tube which has two basic points of difference from the 3A3 tube. First, the 3A2 tube is of the miniature tube design and uses a 9-pin base (Fig. 26). Second, it is designed to withstand an inverse voltage of 18 KV.

Advertising Index

American Microphone Co.	43
American Television & Radio Co.	38
Bussmann Mfg. Co.	5
CBS-Hytron	6
Channel Master Corp.	11
Chicago Standard Transformer Corp.	41
Clarostat Mfg. Co., Inc.	44
Crosley Div., Avco Mfg. Co.	12
Federal Telephone & Radio Co.	Cover 3
International Resistance Co.	Cover 2
Jensen Manufacturing Co.	1
Mosley Electronics	44
Quam-Nichols Co.	40
Raytheon Mfg. Co.	2
RCA Tube Dept.	Cover 4
Rider, John F. Publisher	17, 47
Sams, Howard W., & Co., Inc.	45
Sangamo Electric Co.	10
Shure Brothers, Inc.	39
Snyder Manufacturing Co.	48
United Catalog Publishers	40
Windsor Electronic Tube Co.	37

MOVING?

Please
Mail Us
Your Change
of Address
Today

Also include old address and code line, if possible. Thanks.

**RADIO-TELEVISION
SERVICE DEALER**

67 West 44 St., New York 36, N. Y.

NOW

any selenium rectifier
can be replaced with a

Federal

Federal's
COMPACTED · EYELET TYPE
UNIVERSAL LINE

meets all replacement needs
where size is a factor

ONE SOURCE OF SUPPLY

... Federal's Universal and Regular Lines
provide complete coverage of today's
selenium rectifier requirements!

SERVICEMEN! Now you can buy all the selenium rectifier
types you'll ever need ... from *Federal!*

Whatever the make or rating of the rectifier being re-
placed, Federal's new, smaller-size *Universal Line*—or Federal's
Regular Line—will meet all requirements!

The Universal Line's smaller "H" dimension does the
job where space is a factor. The five types are listed below.
All are eyelet construction, with 6/32" mounting screw
enclosed. They are designed to handle approximately 70%
of all replacements.

Make *your* servicing job easier ... more profitable ... by
simplifying rectifier procurement. Get *uniform* quality, de-
pendability and performance—plus *long, long life*—by re-
placing with Federal's *Universal* and *Regular Lines* ... in
the easy-to-identify "Rectifier Red." Ask your distributor,
or write to Dept. F-385.

UNIVERSAL LINE RATINGS AND DIMENSIONS:

Type	Max. DC Ma.	"H" Dim. Max.	Plate Size
1263A	65	21/32" ± 1/32"	11/16" Sq.
1236A	300	1-3/8" ± 1/32"	1-5/8" Sq.
1238A	350	1-3/8" ± 1/32"	1-3/4" Sq.
1241A	400	1-1/4" ± 1/32"	2" Sq.
1237A	500	1-3/8" ± 1/32"	2" Sq.

Federal has available a new type bolt and nut for mounting rectifiers
in tandem. Order bolts by Part No. IDR-6131; nuts by Part No. IDR-6015.

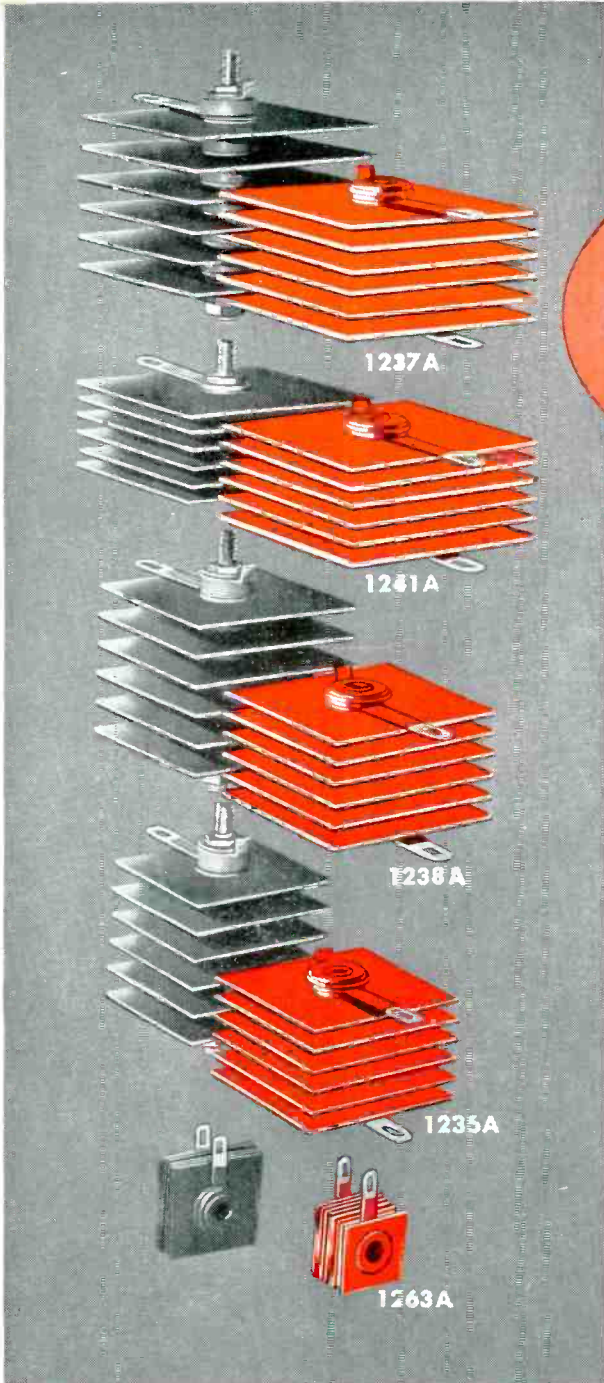

Federal Selenium Rectifiers are listed in
Howard W. Sam's Counter-Facts and Photo Facts

America's first and largest manufacturer of selenium rectifiers

Federal Telephone and Radio Company

A Division of INTERNATIONAL TELEPHONE AND TELEGRAPH CORPORATION
COMPONENTS DIVISION 100 KINGSLAND ROAD CLIFTON, N. J.
In Canada: Federal Electric Manufacturing Company, Ltd., Montreal, P. Q.
Export Distributors: International Standard Electric Corp., 67 Broad St., N. Y.



Federal
"S-C-S"
GERMANIUM
DIODES!
—in the industry's
most useful
PACKAGE LINE!
Ask your
Distributor!

2A 30 560 MAY 58
ALEX RADIO LAB
A PLAKADIS PROP
1701 W 25TH ST
CLEVELAND OH 43113

Get ready for

COLOR TV

Now at no extra cost to you
the famous **RCA INSTITUTES**



HOME STUDY COURSE IN COLOR TV

with your purchase of RCA Tubes

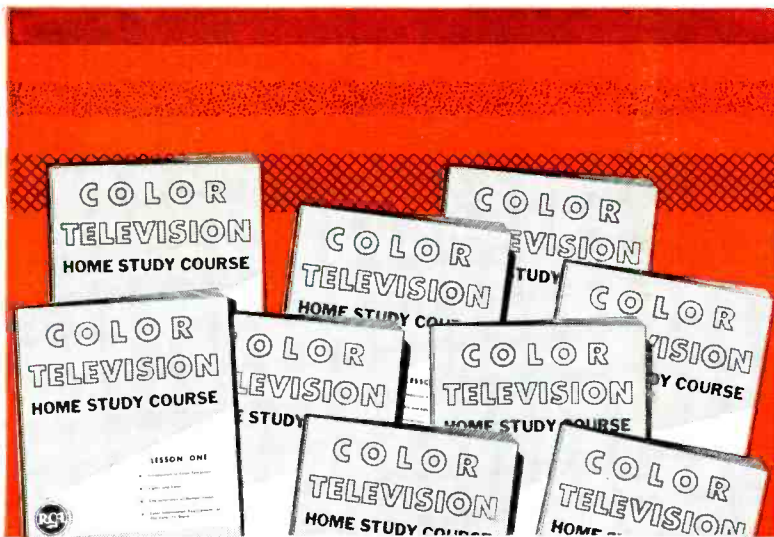

LOOK WHAT YOU GET...

GROUP I—COLOR TV THEORY

1. Introduction to Color Television
2. Principles of Two-Phase Modulation and Colorimetry
3. Principles of Color TV Receivers

GROUP II—COLOR TV RECEIVERS

4. Color Kinescopes
5. The Color Television System
6. Color TV Receiver Circuits

GROUP III—COLOR TV SERVICING

7. Set-up and Adjustment of Color TV Receivers
8. Servicing and Alignment of Color TV Receivers
9. Test Equipment for Color TV Servicing

Here is an outstanding offer which can put your service business out front in your neighborhood. Here is an opportunity to learn more about color TV . . . quickly . . . thoroughly from the famous RCA Institutes. When you buy RCA Tubes, you can earn a complete, 9-step Home Study Course on Color TV at no extra cost. This is your chance to improve your outlook for COLOR TV profits *now* before this big business gets into full swing.

Remember—the RCA Institutes Home Study

Course in Color Television is an *advanced course*, written expressly for experienced television technicians who want to be prepared for the specialized business of Color TV servicing. Remember also that RCA pioneered and developed compatible Color Television.

Act today on this progressive offer. Ask your RCA Distributor Salesman for complete details as to how you can earn the RCA Institutes Color TV Home Study Course FREE with your purchases of RCA Tubes.

ACT NOW!— Offer expires November 15, 1954.



RADIO CORPORATION of AMERICA
ELECTRON TUBES

HARRISON, N. J.